

Repair, Parts



BRITE STRIPER 3500SP

Airless Line Striper

3A4558B
EN

For the application of line striping materials. For professional use only. For outdoor use only. Not approved for use in explosive atmospheres or hazardous locations.

Model: 25M230

3300 psi (22.8 MPa, 228 bar) Maximum Operating Pressure



Important Safety Instructions

Read all warnings and instructions in this manual, related manuals, and on the equipment. Be familiar with the controls and the proper usage of the equipment. Save these instructions.

| Related Manuals: | |
|------------------|-----------|
| 3A4557 | Operation |
| 3A4408 | Gun |
| 3A4347 | Pump |

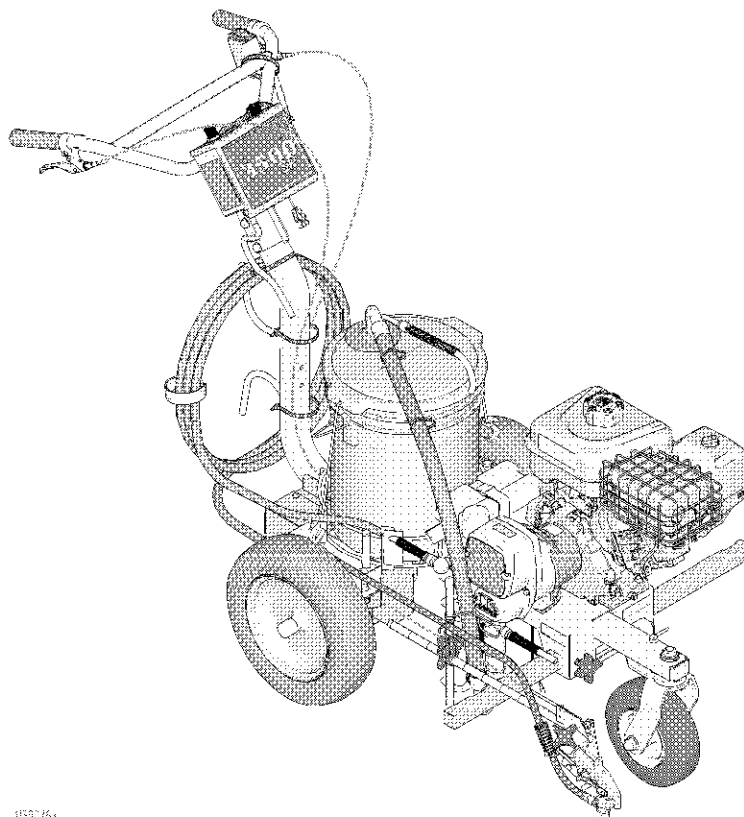











159276

Contents









| | | | |
|---|-----------|---|-----------|
| Warnings | 3 | Drive Motor | 22 |
| Grounding Procedure (For Flammable Materials Only) | 6 | Removal | 22 |
| Pressure Relief Procedure | 6 | Installation | 24 |
| Maintenance | 7 | Drive Wheels | 26 |
| Front Wheel Alignment: | 7 | Removal | 26 |
| Troubleshooting | 8 | Installation | 26 |
| Displacement Pump | 10 | Drive Switch | 27 |
| Removal | 10 | Removal | 27 |
| Repair | 10 | Installation | 28 |
| Installation | 11 | Drive/Axle Bearings | 29 |
| Drive Housing and Connecting Rod | 12 | Removal | 29 |
| Removal | 12 | Installation | 30 |
| Installation | 12 | Drive Chain | 32 |
| Pinion Assembly/Clutch Armature/Clamp | 13 | Removal | 32 |
| Pinion Assembly/Clutch Armature Removal | 13 | Installation | 32 |
| Installation | 14 | Motor Control Board | 33 |
| Clamp Removal | 15 | Removal | 33 |
| Clamp Installation | 15 | Installation | 34 |
| Clutch Housing | 16 | Speed Control | 35 |
| Removal | 16 | Removal | 35 |
| Installation | 16 | Installation | 36 |
| Engine | 17 | Troubleshooting | 37 |
| Removal | 17 | Drive System | 37 |
| Installation | 17 | Fluid Pump Runs Constantly | 38 |
| Pressure Control Transducer | 18 | Control Board Malfunction | 39 |
| Removal | 18 | Control Board Malfunction (Steps) | 40 |
| Installation | 18 | Digital Display Messages | 41 |
| Pressure Control (On/Off Switch) | 19 | Parts Drawing | 42 |
| Removal | 19 | 25M230 | 42 |
| Installation | 19 | Parts List - 25M230 | 43 |
| Pressure Adjust Potentiometer | 20 | Parts Drawing | 44 |
| Removal | 20 | Self-Propelled Drive | 44 |
| Installation | 20 | Parts List - Self-Propelled Drive | 45 |
| Control Board | 20 | Parts Drawing | 46 |
| Removal | 20 | Parts List - 25M230 | 47 |
| Installation | 20 | Parts Drawing and List - Pinion Housing | 48 |
| Battery | 21 | Gun Arm Parts | 49 |
| Removal | 21 | Pressure Control/Filter Assembly | 50 |
| Installation | 22 | Parts List - Pressure Control/Filter Assembly .. | 51 |
| | | Pressure Control Wiring Diagram | 52 |
| | | Drive Control Wiring Diagram | 53 |
| | | PIONEER LIMITED WARRANTY | 54 |



Warnings

The following warnings are for the setup, use, grounding, maintenance, and repair of this equipment. The exclamation point symbol alerts you to a general warning and the hazard symbols refer to procedure-specific risks. When these symbols appear in the body of this manual or on warning labels, refer back to these Warnings. Product-specific hazard symbols and warnings not covered in this section may appear throughout the body of this manual where applicable.

|  WARNING | |
|--|--|
|      | <p>SKIN INJECTION HAZARD</p> <p>High-pressure spray is able to inject toxins into the body and cause serious bodily injury. In the event that injection occurs, get immediate surgical treatment.</p> <ul style="list-style-type: none"> • Do not aim the gun at, or spray any person or animal. • Keep hands and other body parts away from the discharge. For example, do not try to stop leaks with any part of the body. • Always use the nozzle tip guard. Do not spray without nozzle tip guard in place. • Use Graco nozzle tips. • Use caution when cleaning and changing nozzle tips. In the case where the nozzle tip clogs while spraying, follow the Pressure Relief Procedure for turning off the unit and relieving the pressure before removing the nozzle tip to clean. • Equipment maintains pressure after power is shut off. Do not leave the equipment energized or under pressure while unattended. Follow the Pressure Relief Procedure when the equipment is unattended or not in use, and before servicing, cleaning, or removing parts. • Check hoses and parts for signs of damage. Replace any damaged hoses or parts. • This system is capable of producing 3300 psi. Use Graco replacement parts or accessories that are rated a minimum of 3300 psi. • Always engage the trigger lock when not spraying. Verify the trigger lock is functioning properly. • Verify that all connections are secure before operating the unit. • Know how to stop the unit and bleed pressure quickly. Be thoroughly familiar with the controls. |
|     | <p>FIRE AND EXPLOSION HAZARD</p> <p>Flammable fumes, such as solvent and paint fumes, in work area can ignite or explode. Paint or solvent flowing through the equipment can cause static sparking. To help prevent fire and explosion:</p> <ul style="list-style-type: none"> • Use equipment only in well ventilated area. • Do not fill fuel tank while engine is running or hot; shut off engine and let it cool. Fuel is flammable and can ignite or explode if spilled on hot surface. • Eliminate all ignition sources; such as pilot lights, cigarettes, portable electric lamps, and plastic drop cloths (potential static sparking). • Ground all equipment in the work area. See Grounding instructions. • Never spray or flush solvent at high pressure. • Keep work area free of debris, including solvent, rags and gasoline. • Do not plug or unplug power cords, or turn power or light switches on or off when flammable fumes are present. • Use only grounded hoses. • Hold gun firmly to side of grounded pail when triggering into pail. Do not use pail liners unless they are anti-static or conductive. • Stop operation immediately if static sparking occurs or you feel a shock. Do not use equipment until you identify and correct the problem. • Keep a working fire extinguisher in the work area. |

⚠ WARNING

| | |
|--|---|
|   | <p>EQUIPMENT MISUSE HAZARD Misuse can cause death or serious injury.</p> <ul style="list-style-type: none"> • Do not operate the unit when fatigued or under the influence of drugs or alcohol. • Do not exceed the maximum working pressure or temperature rating of the lowest rated system component. See Technical Data in all equipment manuals. • Use fluids and solvents that are compatible with equipment wetted parts. See Technical Data in all equipment manuals. Read fluid and solvent manufacturer's warnings. For complete information about your material, request Safety Data Sheet (SDS) from distributor or retailer. • Do not leave the work area while equipment is energized or under pressure. • Turn off all equipment and follow the Pressure Relief Procedure when equipment is not in use. • Check equipment daily. Repair or replace worn or damaged parts immediately with genuine manufacturer's replacement parts only. • Do not alter or modify equipment. Alterations or modifications may void agency approvals and create safety hazards. • Make sure all equipment is rated and approved for the environment in which you are using it. • Use equipment only for its intended purpose. Call your distributor for information. • Route hoses and cables away from traffic areas, sharp edges, moving parts, and hot surfaces. • Do not kink or over bend hoses or use hoses to pull equipment. • Keep children and animals away from work area. • Comply with all applicable safety regulations. |
|   | <p>MOVING PARTS HAZARD</p> <p>Moving parts can pinch, cut, or amputate fingers and other body parts.</p> <ul style="list-style-type: none"> • Keep clear of moving parts. • Do not operate equipment with protective guards or covers removed. • Pressurized equipment can start without warning. Before checking, moving, or servicing equipment, follow the Pressure Relief Procedure and disconnect all power sources. |
|  | <p>ENTANGLEMENT HAZARD</p> <p>Rotating parts can cause serious injury.</p> <ul style="list-style-type: none"> • Keep clear of moving parts. • Do not operate equipment with protective guards or covers removed. • Do not wear loose clothing, jewelry or long hair while operating equipment. • Equipment can start without warning. Before checking, moving, or servicing equipment, remove fuse near battery. |
|  | <p>CARBON MONOXIDE HAZARD</p> <p>Exhaust contains poisonous carbon monoxide, which is colorless and odorless. Breathing carbon monoxide can cause death.</p> <ul style="list-style-type: none"> • Do not operate in an enclosed area. |
|  | <p>TOXIC FLUID OR FUMES HAZARD</p> <p>Toxic fluids or fumes can cause serious injury or death if splashed in the eyes or on skin, inhaled, or swallowed.</p> <ul style="list-style-type: none"> • Read SDS to know the specific hazards of the fluids you are using. • Store hazardous fluid in approved containers, and dispose of it according to applicable guidelines. |
|  | <p>BURN HAZARD</p> <p>Equipment surfaces and fluid that's heated can become very hot during operation. To avoid severe burns:</p> <ul style="list-style-type: none"> • Do not touch hot fluid or equipment. |

|  WARNING | |
|--|--|
|  | <p>PERSONAL PROTECTIVE EQUIPMENT</p> <p>Wear appropriate protective equipment when in the work area to help prevent serious injury, including eye injury, hearing loss, inhalation of toxic fumes, and burns. This protective equipment includes but is not limited to:</p> <ul style="list-style-type: none"> • Protective eyewear, and hearing protection. • Respirators, protective clothing, and gloves as recommended by the fluid and solvent manufacturer. |
| | <p>CALIFORNIA PROPOSITION 65</p> <ul style="list-style-type: none"> • The engine exhaust from this product contains a chemical known to the state of California to cause cancer, birth defects or other reproductive harm. • This product contains a chemical known to the State of California to cause cancer, birth defects or other reproductive harm. Wash hands after handling. |

Grounding Procedure (For Flammable Materials Only)

| | | | | |
|--|--|--|--|--|
| | | | | |
|--|--|--|--|--|

This equipment must be grounded to reduce the risk of static sparking. Static sparking can cause fumes to ignite or explode. Grounding provides an escape wire for the electric current.

1. Position striper so that the tires are not on pavement.
2. Striper is shipped with a grounding clamp. Grounding clamp must attach to grounded object. (e.g. metal sign post).

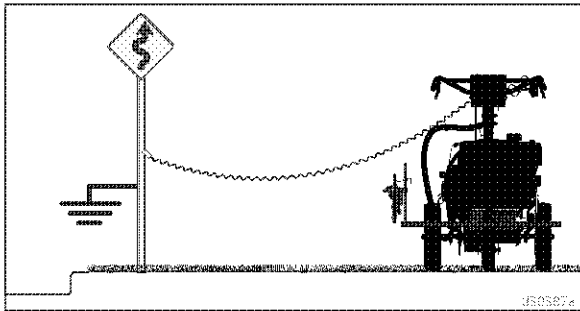

Pressure Relief Procedure



Follow the **Pressure Relief Procedure** whenever you see this symbol.

| | | | | |
|--|--|--|--|--|
| | | | | |
| | | | | |

This equipment stays pressurized until pressure is manually relieved. To help prevent serious injury from pressurized fluid, such as skin injection, splashed fluid and moving parts, follow the **Pressure Relief Procedure** whenever sprayer is stopped and before sprayer is cleaned or checked, and before equipment is serviced.

1. Perform **Grounding Procedure** if using flammable materials.
2. Set pump switch **OFF**. Turn engine **OFF** by pressing the engine kill switch at the controls, or by moving the lever on the engine.

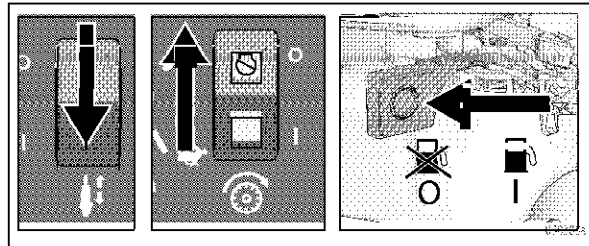

3. Turn pressure to lowest setting. Trigger gun to relieve pressure.

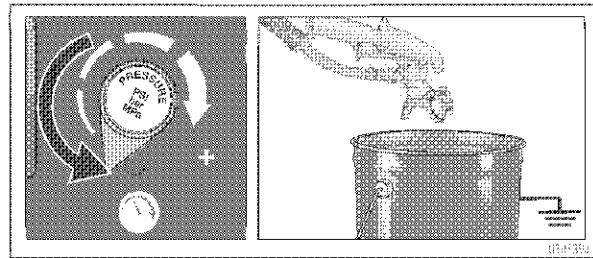

4. Engage the trigger lock. Turn prime valve down.

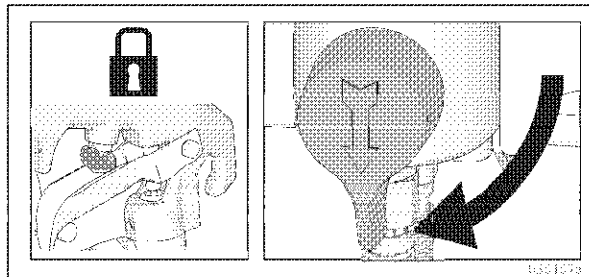

5. If you suspect the spray tip or hose is clogged or that pressure has not been fully relieved:
 - a. **VERY SLOWLY** loosen tip guard retaining nut or hose end coupling to relieve pressure gradually.
 - b. Loosen nut or coupling completely.
 - c. Clear hose or tip obstruction.

Maintenance

DAILY: Check hose for wear and damage.

DAILY: Check gun safety for proper operation.

DAILY: Check pressure drain valve for proper operation.

DAILY: Check and fill the gas tank.

DAILY: Check level of TSO in displacement pump packing nut. Fill nut, if necessary. Keep TSO in nut to help prevent fluid buildup on piston rod and premature wear of packings and pump corrosion.

Engine Maintenance Schedule

FIRST 5 HOURS: Change oil

EVERY 8 HOURS OR DAILY:

- Check engine oil level.
- Clean area around muffler and controls.
- Clean air intake grille.

EVERY 25 HOURS OR ANNUALLY:

- Clean air filter.
- Clean pre-cleaner.

EVERY 50 HOURS OR ANNUALLY:

- Change engine oil.
- Service exhaust system.

EVERY 100 HOURS: Change gear reduction oil (if equipped)

ANNUALLY:

- Replace spark plug.
- Replace air filter.
- Replace pre-cleaner.
- Service fuel system.
- Service cooling system.
- Check valve clearance.

SPARK PLUG: Use only Briggs & Stratton 491055S or Champion RC-12YC spark plug. Gap plug to 0.030 in. (0.762mm). Use spark plug wrench when installing and removing plug.

Front Wheel Alignment:

Align front wheel as follows:

1. Loosen cap screw (114).

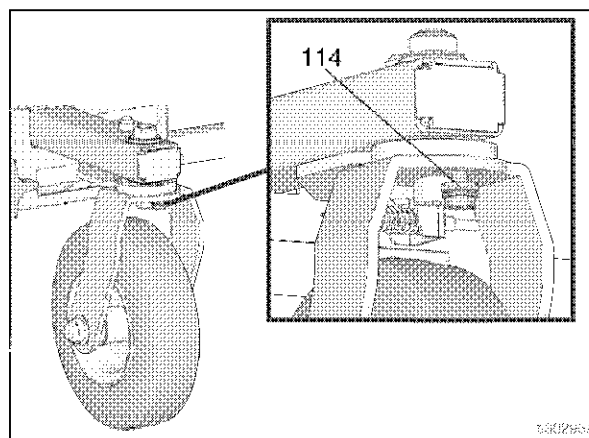

2. Position front wheel left or right, as necessary, to straighten alignment.
3. Tighten cap screw. Push striper and let striper roll with hands off of striper.

NOTE: If striper veers right or left, repeat steps 1 and 2 until striper rolls straight.

Troubleshooting

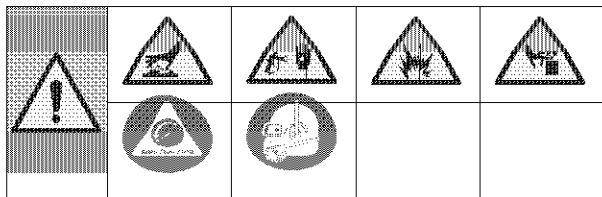

| Problem | Cause | Solution |
|---|--|--|
| Engine won't start | Engine is out of gas | Refill gas tank. Briggs & Stratton Owner's Manual. |
| | Engine oil level is low | Check oil level. Replenish oil, if necessary. Briggs & Stratton Owner's Manual. |
| | Spark plug is disconnected or damaged | Connect spark plug cable or replace spark plug. |
| | Cold engine | Use choke |
| | Fuel shutoff / Engine kill switch is OFF | Move lever to ON position. |
| | Oil is seeping into combustion chamber | Remove spark plug. Pull starter 3 to 4 times. Clean or replace spark plug. Start engine. Keep sprayer upright to avoid oil seepage |
| Engine operates, but displacement pump does not operate | Pump switch is OFF | Turn pump switch ON |
| | Pressure setting too low | Turn pressure adjusting knob clockwise to increase pressure |
| | Fluid filter is dirty | Clean filter |
| | Tip or tip filter is clogged | Clean tip or tip filter (see gun manual) |
| | Displacement pump piston rod is stuck due to dried paint | Repair pump (see pump manual) |
| | Connecting rod is worn or damaged | See parts manual |
| | Drive housing is worn or damaged | See parts manual |
| | Electrical power is not energizing clutch field | See parts manual Reference pressure control repair. Pages 18, 19, 20. Reference wiring diagram. Page 52. With pump switch ON and pressure turned to MAXIMUM, use a test light to check for power between clutch test points on control board. Remove clutch wires from control board and measure resistance across clutch coil. At 70°F, the resistance must be between 1.2+0.2 ohms; if not, replace pinion housing Have pressure control checked by authorized dealer |
| | Clutch is worn, damaged, or incorrectly positioned | Adjust or replace clutch. Page 13. |
| Pinion assembly is worn or damaged | Repair or replace pinion assembly. Page 13. | |

| Problem | Cause | Solution |
|---|--|---|
| Pump output is low | Strainer is clogged | Clean strainer. See pump manual. |
| | Piston ball is not seating | Service piston ball. See pump manual. |
| | Piston packings are worn or damaged | Replace packings. See pump manual. |
| | O-ring in pump is worn or damaged | Replace o-ring. See pump manual. |
| | Intake valve ball is not seating properly | Clean intake valve. See pump manual. See operations manual. |
| | Intake valve ball is packed with material | Clean intake valve. See operations manual. |
| | Engine speed is too low | Increase pressure. See operations manual. |
| | Clutch is worn or damaged | Adjust or replace clutch. Page 13. |
| | Pressure setting is too low | Increase pressure. See operations manual. |
| | Fluid filter, tip filter or tip is clogged or dirty | Clean filter. See operations manual. |
| | Large pressure drop in hose with heavy materials | Use larger diameter hose and/or reduce overall length of hose. Use of more than 100 ft. of 1/4 in. hose significantly reduces performance of sprayer. Use 3/8 in. hose for optimum performance (50 ft. minimum) |
| Excessive paint leakage into throat packing nut | Throat packing nut is loose | Remove throat packing nut spacer. Tighten throat packing nut just enough to stop leakage. |
| | Throat packings are worn or damaged | Replace packings. See pump manual. |
| | Displacement rod is worn or damaged | Replace rod. See pump manual. |
| Fluid is spitting from gun | Air in pump or hose | Check and tighten all fluid connections. Reprime pump. See operations manual. |
| | Tip is partially clogged | Clear tip. See gun manual. |
| | Fluid supply is low or empty | Refill fluid supply. Prime pump. See operations manual. Check fluid supply often to prevent running pump dry. |
| Pump is difficult to prime | Air in pump or hose | Check and tighten all fluid connections. Reduce engine speed and cycle pump as slowly as possible during priming. |
| | Intake valve is leaking | Clean intake valve. Be sure ball seat is not nicked or worn and that ball seats well. Reassemble valve. |
| | Pump packings are worn | Replace pump packings. See pump manual. |
| | Paint is too thick | Thin the paint according to the supplier's recommendations |
| | Engine speed is too high | Decrease throttle setting before priming pump. See operations manual. |
| Clutch squeaks each time clutch engages | Clutch surfaces are not matched to each other when new and may cause noise | Clutch surfaces need to wear into each other. Noise will dissipate after a day of run time. |
| High engine speed at no load (> 3800 rpm) | Worn engine governor | Replace or service engine governor |

Displacement Pump

Removal



1. Stop pump with piston rod (29) in its lowest position.
2. Perform **Pressure Relief Procedure**, page 6.
3. Loosen two screws (32) and remove pump rod cover (107).

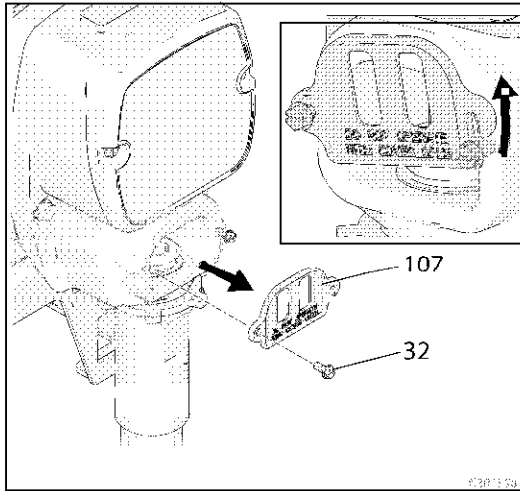

4. Remove hose (118) and suction hose (57). Use screwdriver; push retaining spring (28) up; push out pin (31).

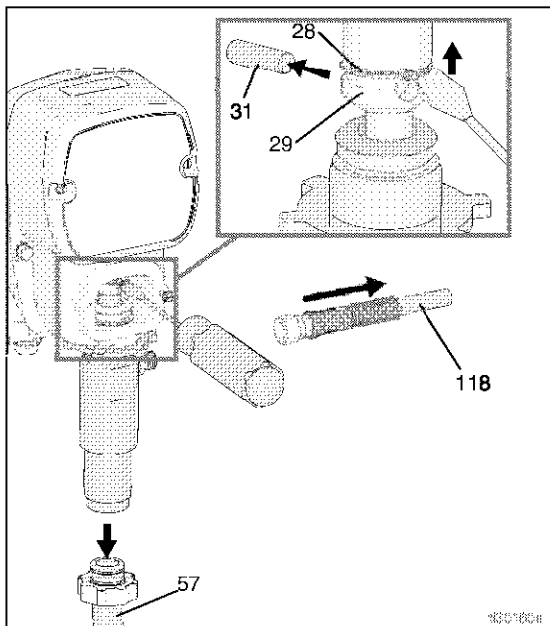

5. Loosen jam nut by hitting firmly with a hammer. Unscrew pump.

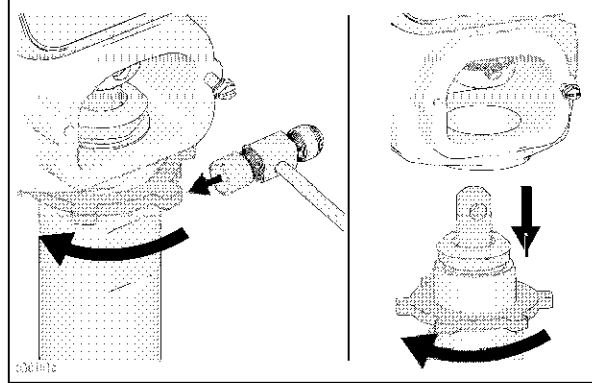

Repair

See manual 3A4347 for pump repair instructions.

Installation

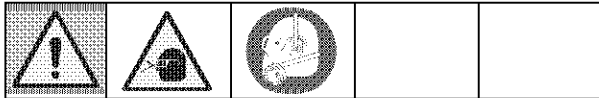

If pin works loose, parts could break off due to force of pumping action. Parts could project through the air and result in serious injury or property damage. Make sure pin and retaining spring are properly installed.

NOTICE

If the pump jam nut loosens during operation, the threads of the bearing housing and drive train will be damaged. Tighten jam nut as specified.

1. Pull piston rod out distance shown. Screw in pump until holes in connecting rod and piston rod align.

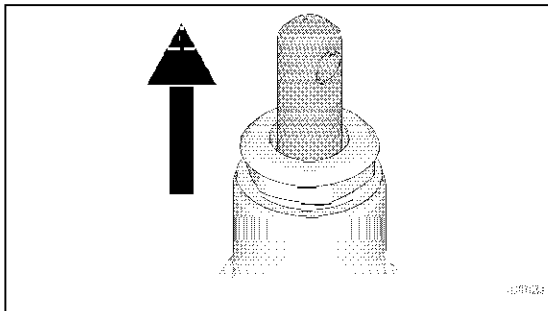

2. Push pin (31) into hole. Push retaining ring spring into groove all the way around connecting rod.

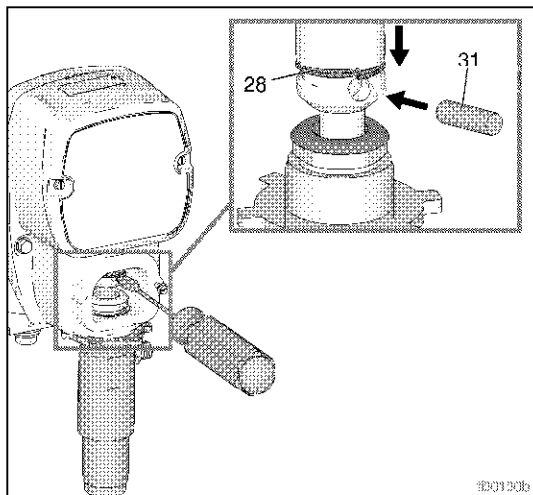

3. Screw jam nut down onto pump until nut stops. Screw pump up into drive housing until top threads of pump are flush with drive housing face. Back off pump and jam nut to align pump outlet to side. Tighten jam nut by hand, then tap 1/8 to 1/4 turn with a 20 oz (maximum) hammer to approximately 75 ±5 ft-lb (102 N-m). Connect hose (118) and suction hose (57).

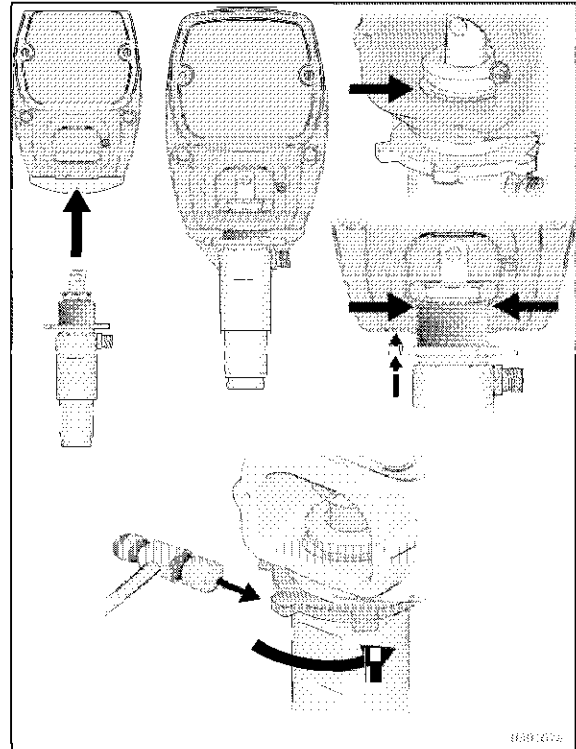

4. Fill packing nut with TSO until fluid flows onto the top of seal. Install pump rod cover (107).

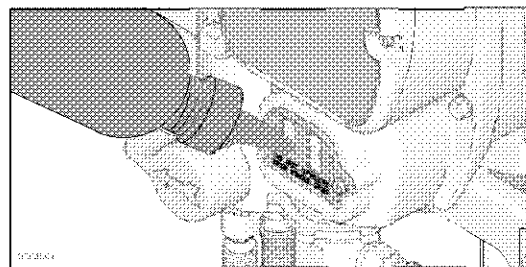

Drive Housing and Connecting Rod

Removal

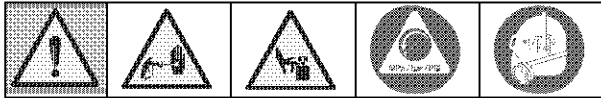

1. Perform **Pressure Relief Procedure**, page 6.
2. Remove screws (32) and front cover (52).
3. Remove pump. Refer to **Displacement Pump**, page 10.
4. Remove four screws (34) from drive housing (43).

NOTICE

Thrust washers may stick to grease inside of drive housing. Do not lose or misplace.

5. Pull connecting rod (29) and lightly tap lower rear of drive housing (43) with plastic mallet to loosen from pinion housing (44). Pull drive housing and connecting rod assembly off pinion housing.
6. Inspect crank (47) and connecting rod (29) for excessive wear and replace parts as needed.

Installation

1. Evenly lubricate inside of bronze bearing (C) in drive housing (43) with high-quality motor oil. Liberally pack top roller bearing (E), lower bearing (D) inside connecting rod (29) with bearing grease.
2. Assemble connecting rod (29) to drive housing (43). Rotate connecting rod to lowest position.
3. Apply grease to washers 46, 49 and 48. Install in order shown.
4. Lubricate gears with 0.26 pint of 110293 grease (supplied with drive housing). Pack grease evenly around gears.
5. Clean mating surfaces of pinion and drive housings.
6. Align connecting rod with crank (47) and carefully align locating pins in drive housing (43) with holes in pinion housing (44). Push drive housing onto pinion housing or tap into place with plastic mallet.

NOTICE

DO NOT use drive housing screws (34) to align or seat bearing housing with drive housing. Align these parts with locating pins to avoid premature bearing wear.

7. Install screws (34) in drive housing. Torque evenly to note 3 value.
8. Install pump. Refer to **Displacement Pump**, page 10.
9. Install front cover (52) with two screws (32).

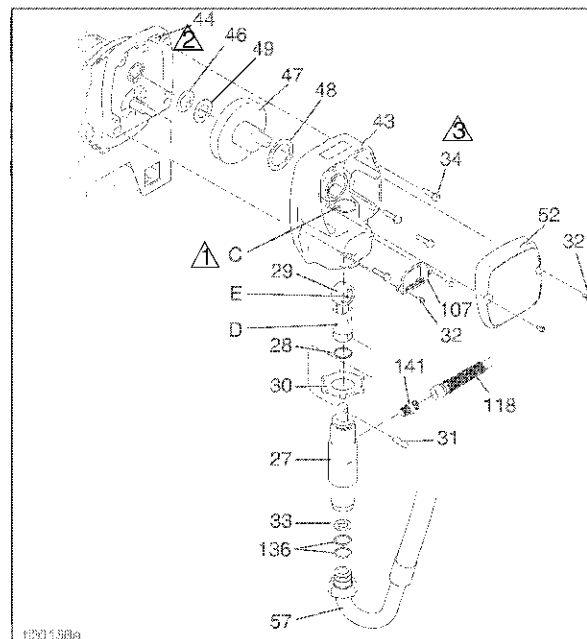

- Oil
- Pack with bearing grease 110293
- Torque to 130-150 in-lb (14-16.9 N•m)

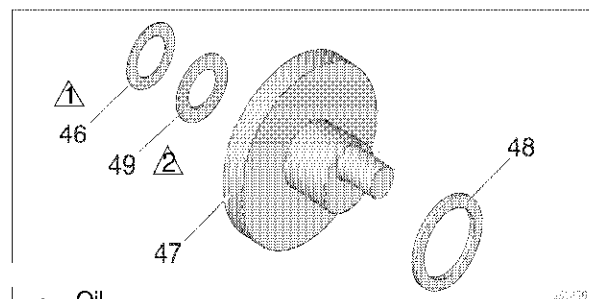

- Oil
- Pack with bearing grease 110293

Pinion Assembly/Clutch Armature/Clamp

Pinion Assembly/Clutch Armature Removal

Pinion Assembly

If pinion assembly (44) is not removed from clutch housing (45), do 1. through 3. Otherwise, start at 4.

1. Remove drive housing. Refer to **Drive Housing and Connecting Rod**, page 12.
2. Disconnect clutch (+) and clutch (-) connectors from wire harness located under sprayer cart.
3. Remove four screws (34) and pinion assembly (44).

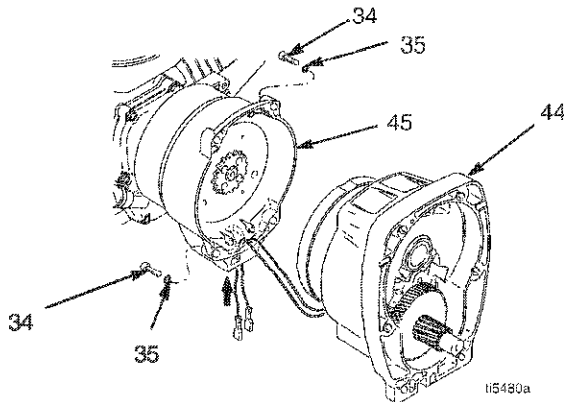

4. Place pinion assembly (44) on bench with rotor side up.

5. Remove four screws (42) and lock washers (35). Install two screws in threaded holes (E) in rotor. Alternately tighten screws until rotor comes off.

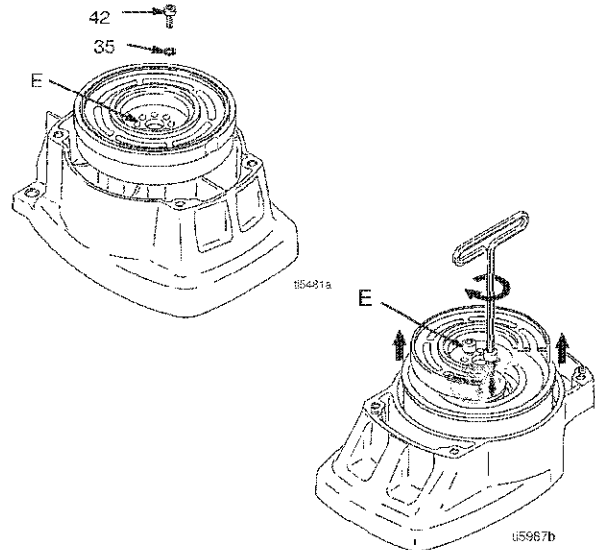

6. Remove retaining ring (44d).
7. Turn pinion assembly over and tap pinion shaft (44c) out with plastic mallet.

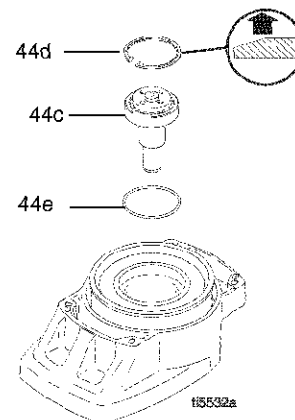

Clutch Armature

8. Use an impact wrench or wedge something between clutch armature (39) and clutch housing to hold engine shaft during removal.
9. Remove four screws (36) and lock washers (35).
10. Remove armature (39).

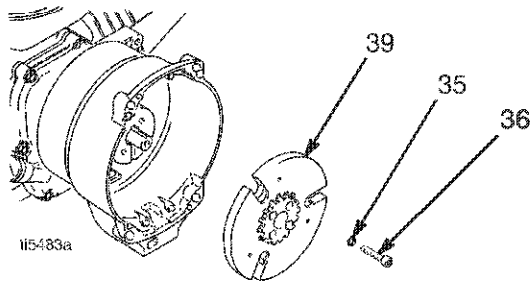

Pinion Assembly

1. Check o-ring (44e) and replace if missing or damaged.
2. Tap pinion shaft (44c) in with plastic mallet.
3. Install retaining ring (44d) with beveled side facing up.
4. Place pinion assembly on bench with rotor side up.
5. Apply blue thread locking liquid to screws. Install four screws (42) and lock washers (35). Alternately torque screws to 125 in-lb until rotor is secure. Use threaded holes to hold rotor.
6. Install pinion assembly (44) with four screws (34) and washers (35).
7. Connect clutch cable connectors to inside of pressure control.

Installation

Clutch Armature

1. Lay two stacks of two dimes on smooth bench surface.
2. Lay armature (39) on two stacks of dimes.
3. Press center of hub (40) down to bench surface.

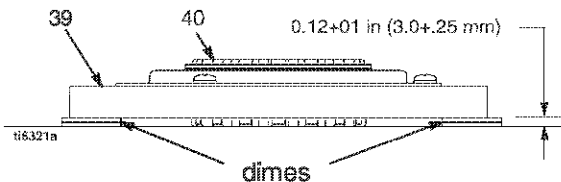

4. Install armature (39) on engine drive shaft.
5. Install four screws (36) and lock washers (35) with torque of 125 in-lb.

Clamp Removal

1. Remove engine. See **Engine Removal**, page 17.
2. Drain gasoline from tank according to Briggs & Stratton manual.
3. Tip engine on side so gas tank is down and air cleaner is up.
4. Loosen two screws (36) on clamp (38).
5. Push screwdriver into slot in clamp (38) and remove clamp.

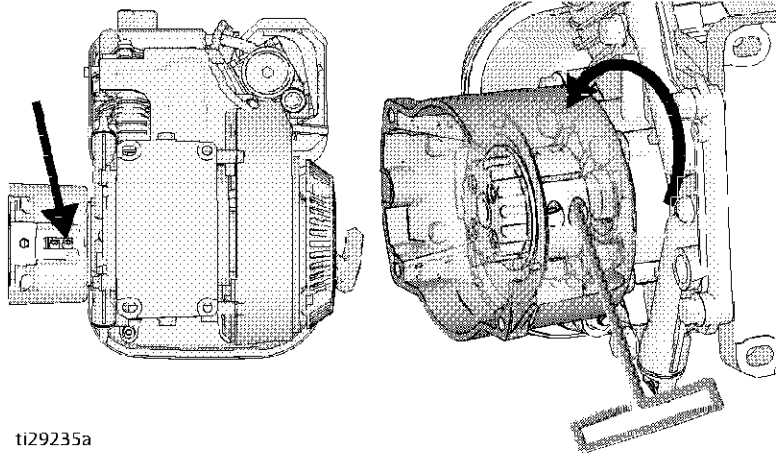

t129235a

Clamp Installation

1. Install engine shaft key (37).
2. Tap clamp (38) onto engine shaft (A). Maintain dimension shown note 2. Chamfer must face engine.
3. Check dimension: Place rigid, straight steel bar (B) across face of clutch housing (45). Use accurate measuring device to measure distance between bar and face of clamp. Adjust clamp as necessary. Torque two screws (36) to 125 ± 10 in-lb (14 ± 1.1 N•m).

- ⚠ Face of clutch housing
- ⚠ $1.550 \pm .010$ in.
($39.37 \pm .25$ mm)
- ⚠ Torque to 125 ± 10 in-lb
(14 ± 1.1 N•m)
- ⚠ Chamfer this side

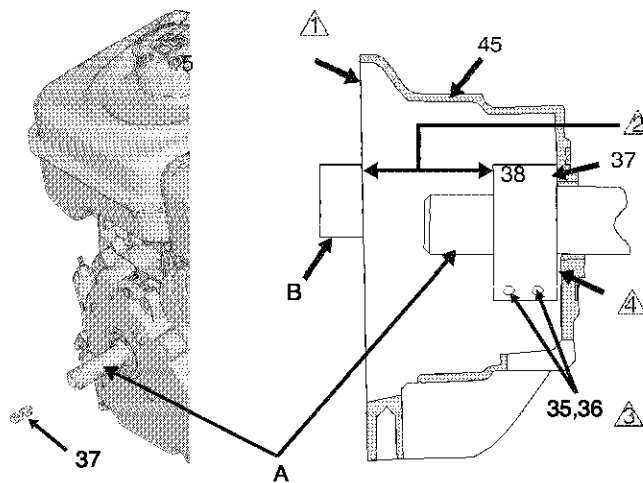

t129237a

Clutch Housing

Removal

1. Remove clamp. Perform **Clamp Removal**, page 15.
2. Remove four screws (51) and lock washers (50) that hold clutch housing (45) to engine.
3. Remove screw (145) from under mounting plate.
4. Pull off clutch housing (45).

Installation

1. Push on clutch housing (45).
2. Install four cap screws (51) and lock washers (50) and secure clutch housing (45) to engine. Torque to 200 in-lb (22.6 N•m).
3. Install screw (145) from beneath mounting plate. Torque to 26 ft-lb (35.2 N•m).

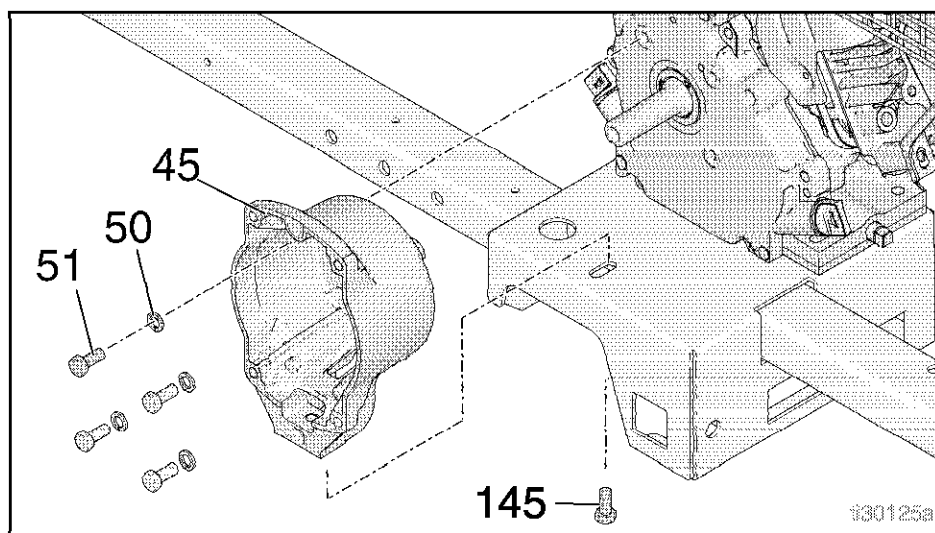

Engine

Removal

NOTE: All service to the engine must be performed by a Briggs & Stratton authorized service dealer.

1. Disconnect all necessary wiring.
2. Remove two lock nuts (111) and screws (110) from base engine, and screw (145) from clutch housing (45)
3. Lift engine carefully and place on work bench.
4. Perform **Clamp Removal**, page 15, and **Clutch Housing Removal**, page 16.

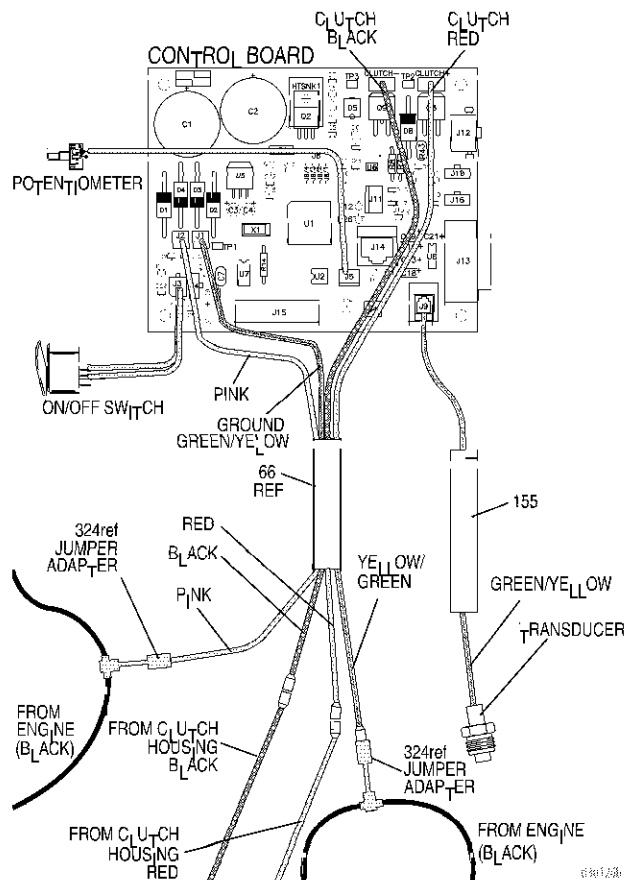
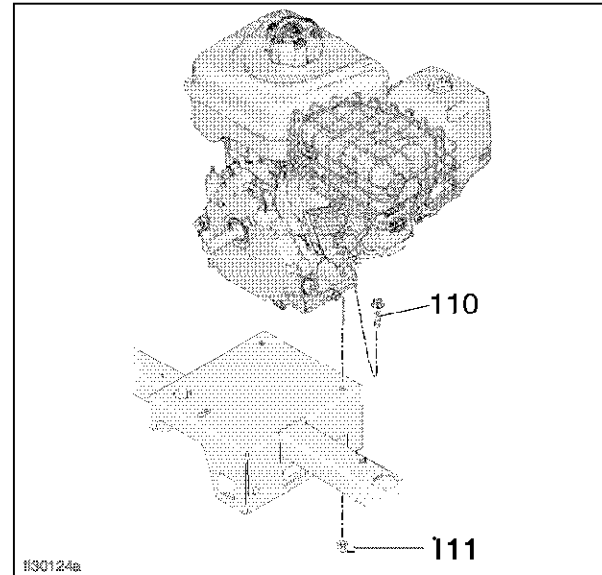

Installation

1. Lift engine carefully and place on cart.
2. Install two screws (110) in base of engine and secure with lock nuts (111). Torque to 20 ft-lb (27.12 Nm),
3. Connect all necessary wiring.
4. Install **Clutch Housing**, page 16, and **Pinion Assembly/Clutch Armature/Clamp**, page 13.

Pressure Control Transducer

Removal

1. Remove two screws (32) and open cover (62a).
2. Disconnect transducer (155) cable from control board (62e).
3. Pull transducer connector through strain relief bushing (151).
4. Remove transducer and o-ring (99) from filter housing (67).

Installation

1. Install o-ring (99) and transducer (155) in filter housing (67). Torque to 35 - 45 ft-lb.
2. Install transducer connector and strain relief bushing in control housing.
3. Connect cable (155) to control board (62e).
4. Close cover (62a) and secure with two screws (32).

Pressure Control (On/Off Switch)

Removal

1. Remove two screws (32) and open cover (62a).
2. Disconnect ON/OFF switch connector from pressure control board (342).
3. Press in on two retaining tabs on each side of ON/OFF switch (62d) and remove switch from cover.

Installation

1. Install new ON/OFF switch (62d) so tabs of switch snap into place on inside of cover.
2. Connect ON/OFF switch connector (B) to pressure control board.
3. Close cover (62a) and secure with two screws (32).

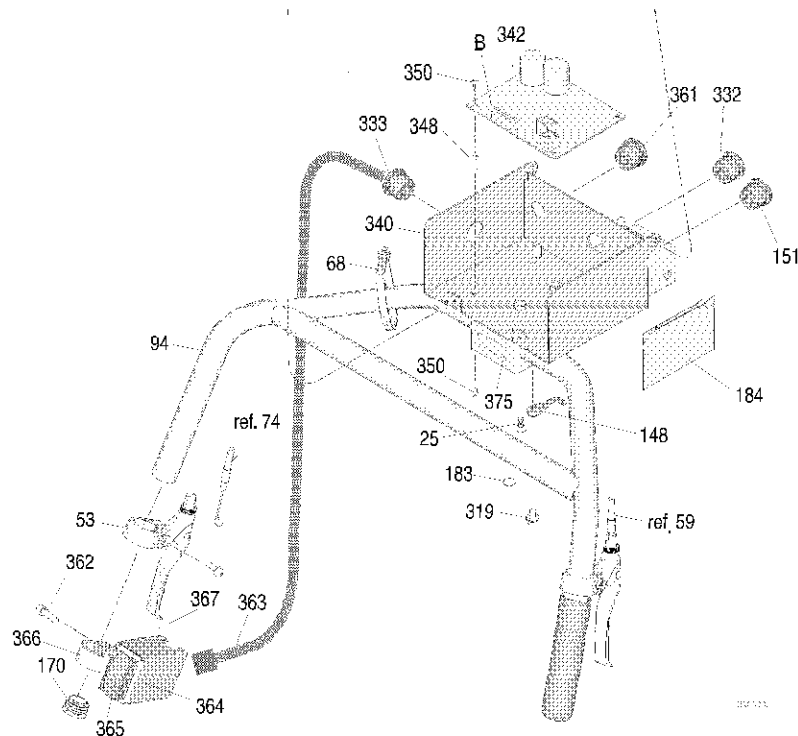
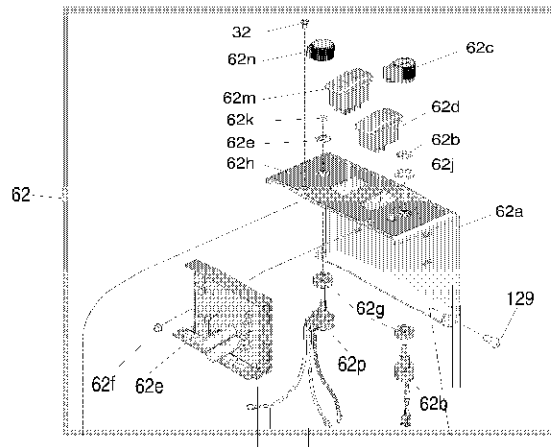

Pressure Adjust Potentiometer

Removal

1. Remove two screws (32) and open cover (62a).
2. Disconnect potentiometer (62b) cable from control board (62e).
3. Loosen set screws on potentiometer knob (62c) and remove knob, shaft nut, lock washer and potentiometer (62b).
4. Remove spacer (62g) from potentiometer.

Installation

1. Install spacer (62g) on potentiometer (62b).
2. Install potentiometer, shaft nut, lock washer and potentiometer knob (62c).
 - a. Turn potentiometer shaft clockwise to internal stop. Assemble potentiometer knob (62c) to touch pin on cover (62a).
 - b. After adjustment of step a., tighten both set screws in knob 1/4 to 3/8 turn after contact with shaft.
3. Connect potentiometer (62b) cable to control board (62e).
4. Close cover (62a) and secure with two screws (32).

Control Board

Removal

1. Remove two screws (32) and open cover (62a).
2. Disconnect engine wires from wire harness (66).
3. Disconnect at control board (62e):
 - Cable from potentiometer (62b)
 - Cable from transducer (155)
 - Cable from ON/OFF switch (62d)
 - Clutch wires
4. Remove four screws (350) and control board (342).

Installation

1. Install control board (342) with four screws (350).
2. Connect at control board (342):
 - Clutch wires
 - Cable from ON/OFF switch (62d)
 - Cable from transducer (155)
 - Cable from potentiometer (62b)
3. Connect engine wires.
4. Close cover (62a) and secure with two screws (32).

Battery

Removal

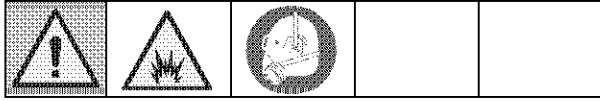

1. Shut off engine, turn off the self-propelled drive system, switch to neutral and engage the parking brake.

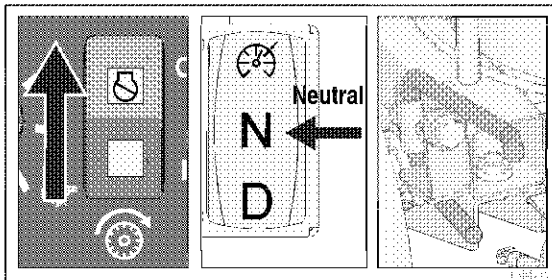

2. Remove battery cover (323).

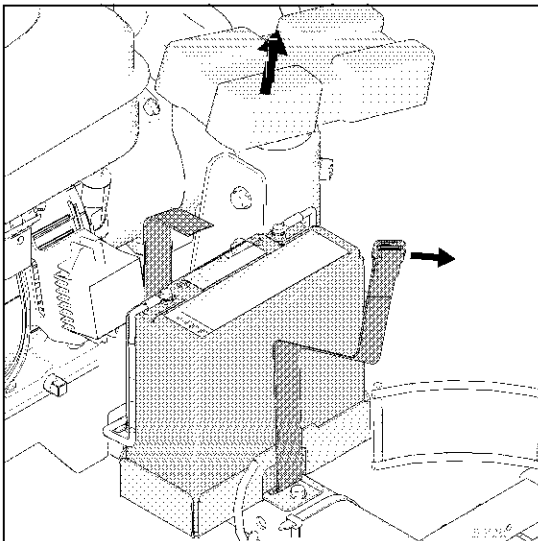

3. Unscrew M5 terminal screws (358) to disconnect battery from wire harness.

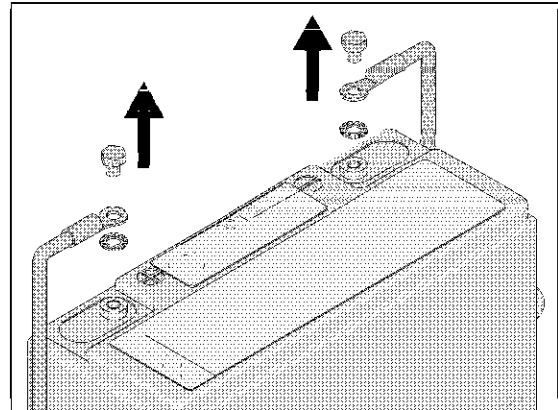

4. Remove battery (321) from bracket (320).

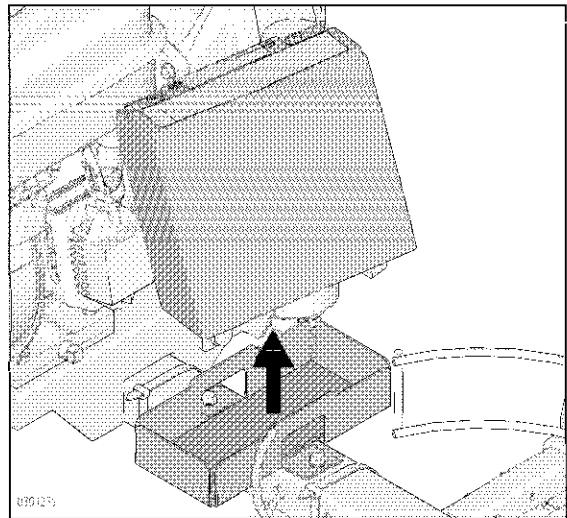

Installation

1. Place battery (321) into bracket (320) and connect the red wire to the positive terminal and the black wire to the negative terminal.

NOTICE

DO NOT reverse the positive and negative battery wires. This will damage the motor control board.

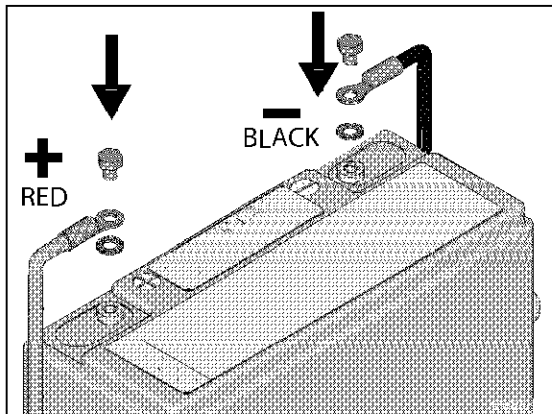

2. Place battery cover (323) and secure with strap (322).

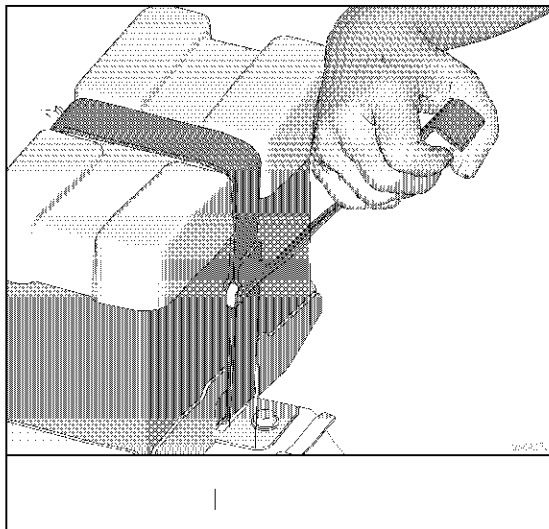

Drive Motor

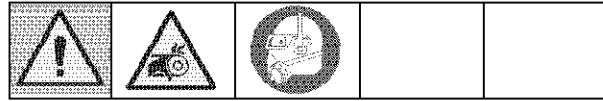

Removal

1. Shut off engine, turn off self-propelled drive system, switch to neutral and engage the parking brake.

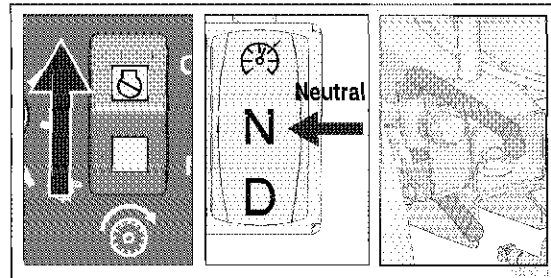

2. Disconnect battery (321) or remove fuse near battery to ensure motor control board (62e) is not powered.

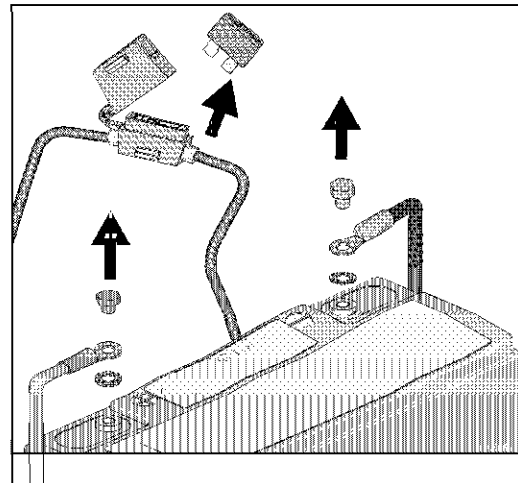

3. Remove the rear chain guard (318).

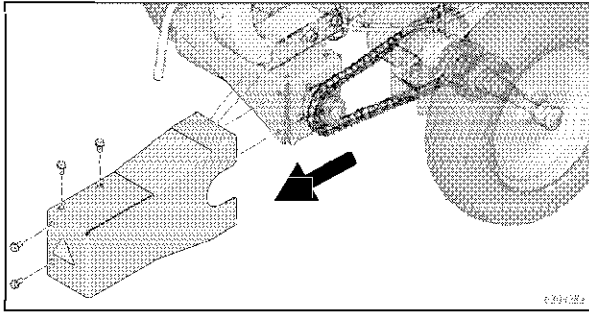

4. Remove the strain relief bushing (361) from the control box so that the motor wires run through, then open the control box cover (62a) and disconnect the yellow motor wire from the motor control board and the blue motor wire from the blue wire that runs up to the handlebar switch (330).

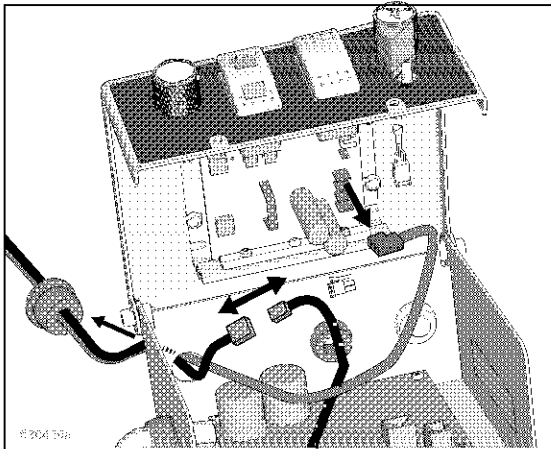

5. Loosen the two bolts (314) that secure the motor mount to the frame and slide the motor completely forward to loosen the chain (316). Loosen the two set screws on the motor sprocket (313).

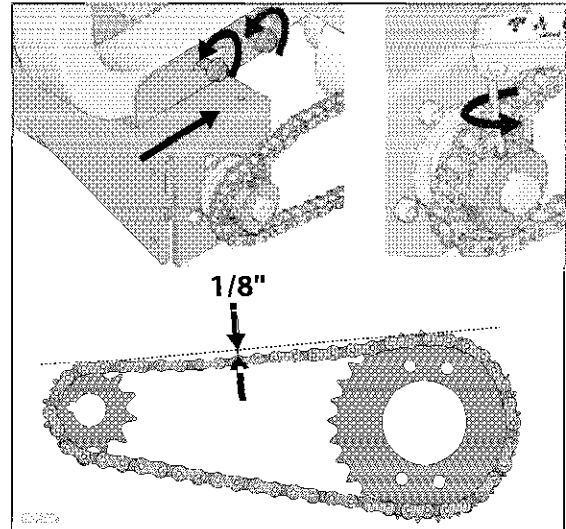

6. Remove the four M6 screws (312) that secure the motor in the motor bracket (310) and slide the sprocket off of the motor shaft while removing the motor (311).

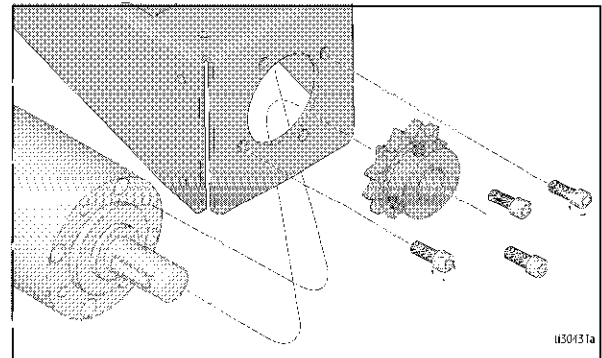

Installation

1. Place a drop of blue thread locking liquid on the threads of each of the four M6 motor screws (312).

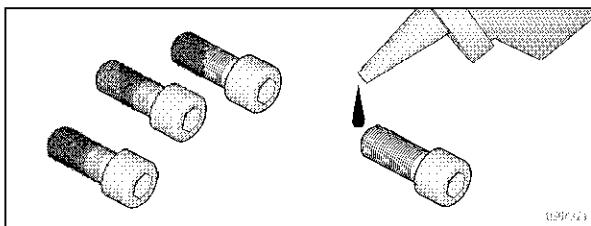

2. With the motor sprocket (313) already placed into the chain (316), slide the sprocket onto the motor shaft while placing the motor (311) into the motor bracket (310), and secure the motor to the motor bracket with four M6 screws (312). Torque to 50-60 in-lb (5.6-6.8 N.m).

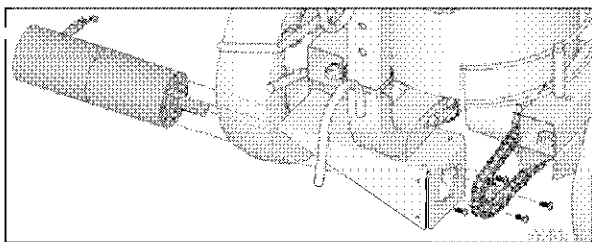

3. Slide the motor bracket (310) back to leave about 1/8" slack in the chain (316), and tighten the motor mount bolts (314). Torque to 30-40 ft-lb (41-54 N.m).

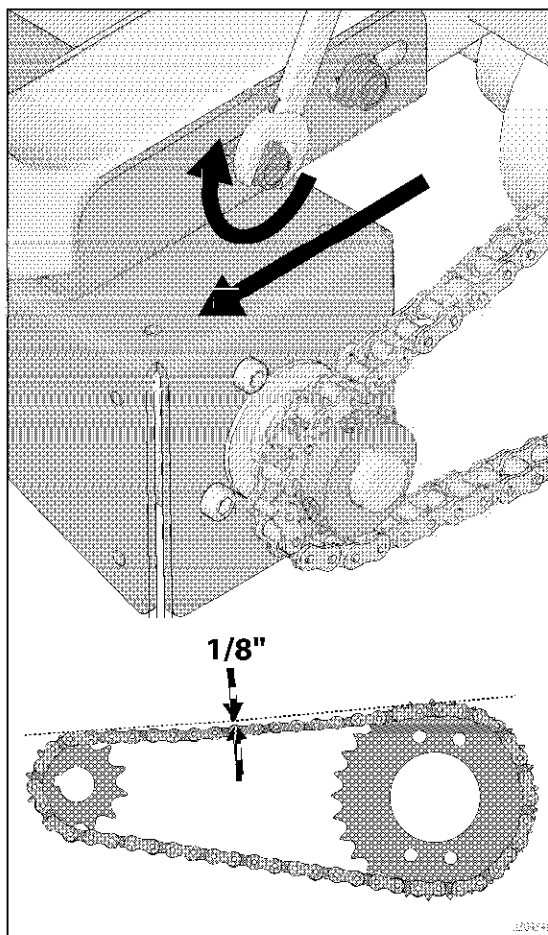

- Adjust the motor sprocket (313) so that it is in-line with the axle sprocket, then place a drop of blue thread locking liquid onto the threads of each set screw and secure the motor sprocket in place. Torque to 50-60 in-lb (5.6-6.8 N·m).

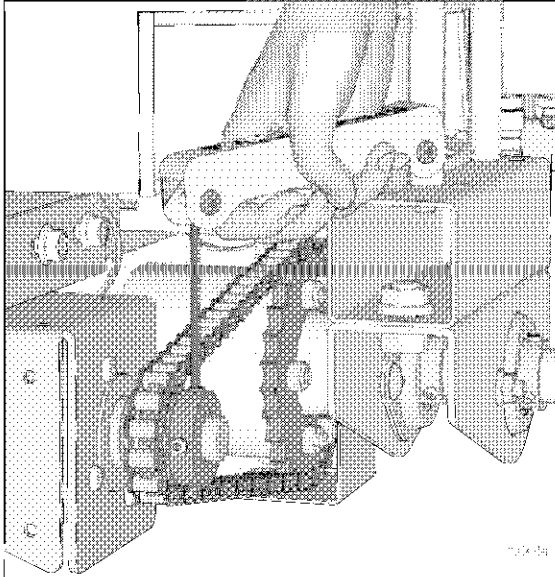

- Run the motor wires into the control box, reconnect wires, secure wires with strain relief bushing and close the control box cover.

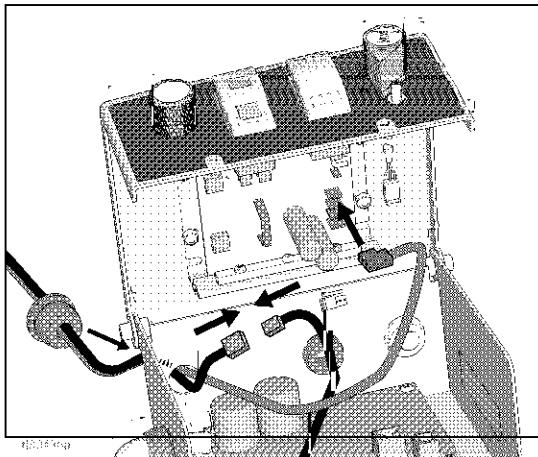

- Reconnect the battery (321) or replace the fuse. Turn ON the self-propelled drive. With the brake ON and the right wheel securely elevated just enough to be off of the ground, run the drive. If any noise or binding occurs at the chain, realign the motor sprocket (313), or adjust the chain slack.

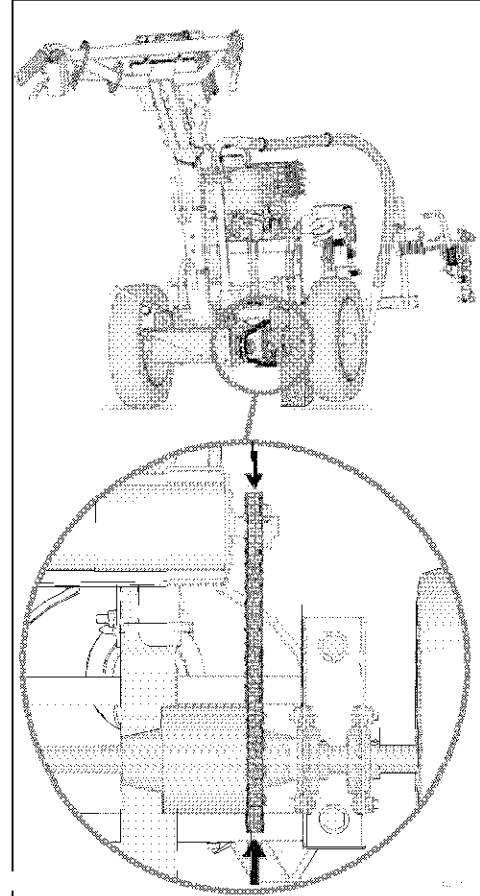

- Turn OFF the self-propelled drive, place in "N", and replace the rear chain guard after sprocket alignment is confirmed.

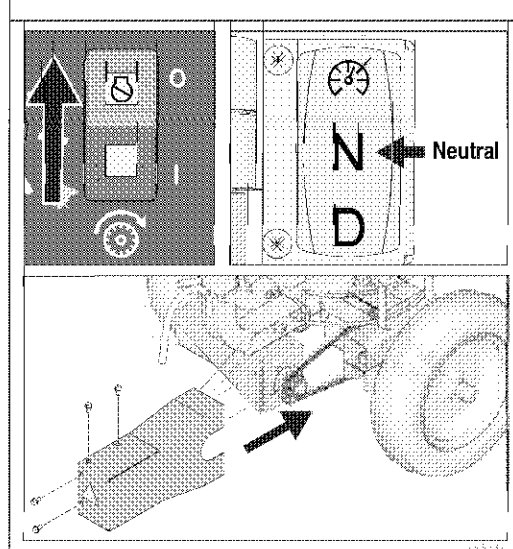

Drive Wheels

Removal

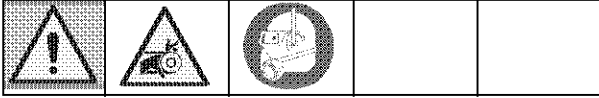

1. Shut off engine and turn off the self-propelled drive system and switch to neutral.

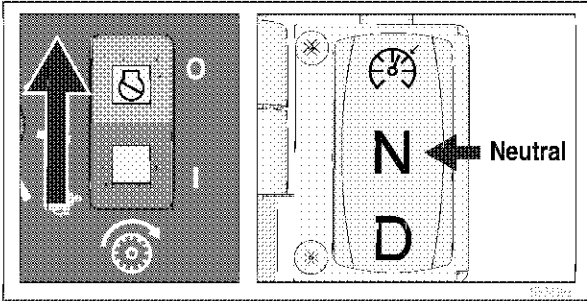

2. Remove bucket or hopper and securely elevate the rear of the striper.

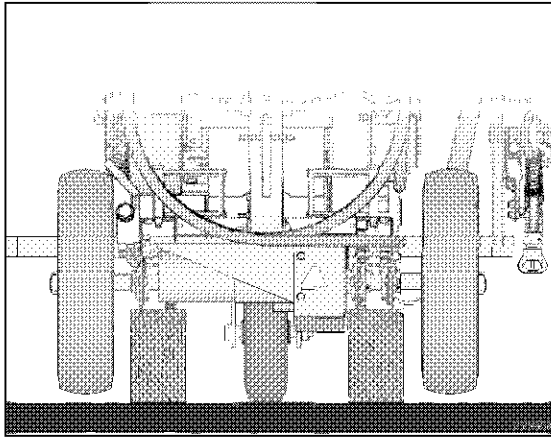

3. While holding the wheel (3) to keep the axle from spinning, loosen and remove the axle nut (307). Slide the wheel off the axle (300) making sure to retain the key (306).

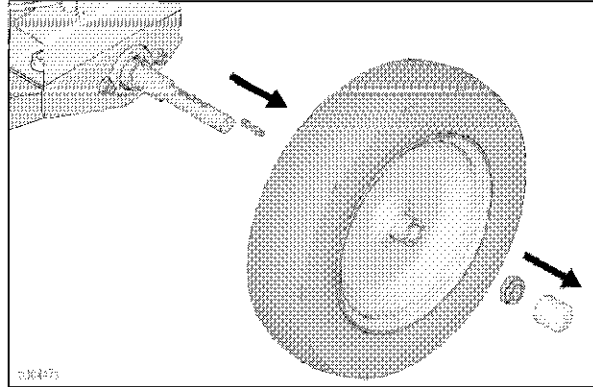

Installation

1. With the key placed into the keyway on the axle, and the keyway on the wheel hub aligned with the key, slide the wheel onto the axle. Install the axle nut and torque to 17-23 ft-lb (23-31 N·m). Replace the axle nut cap (131).

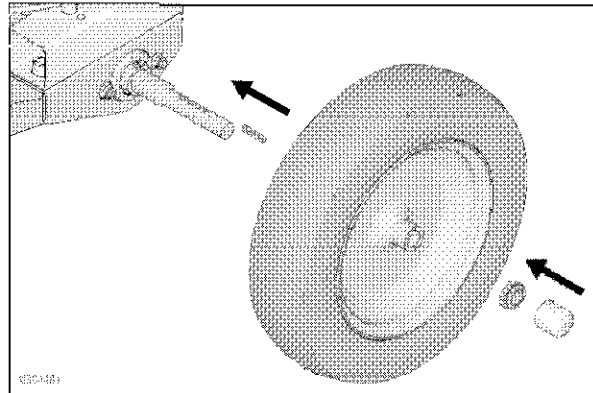

Drive Switch

Removal

1. Shut off engine, turn off self-propelled drive system, switch to neutral and engage the parking brake.

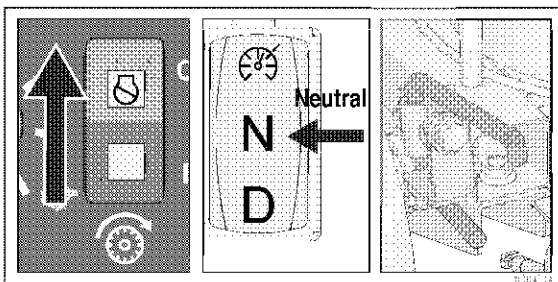

2. Disconnect battery (321) or remove fuse near battery to ensure motor control board (62e) is not powered.

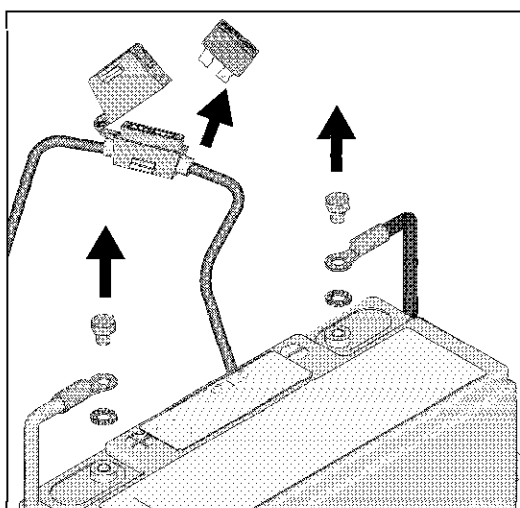

3. Open the control box.

4. Remove the strain relief bushing (333) and disconnect the blue wire from (-A) on the control board and from the blue motor wire. Disconnect the white wire from (HI) on the control board (62e) and from the white wire coming from the speed control.

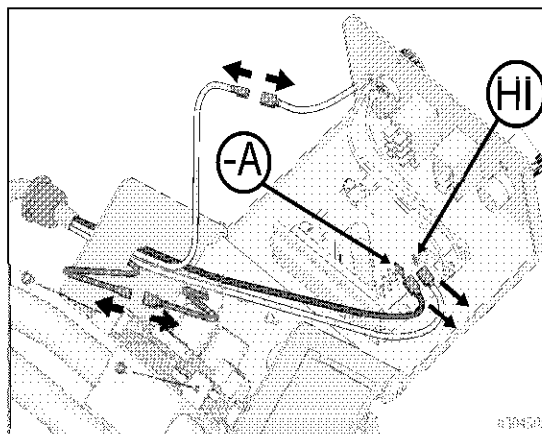

5. Remove the four screws to remove the switch housing, with the switch, from the mount.

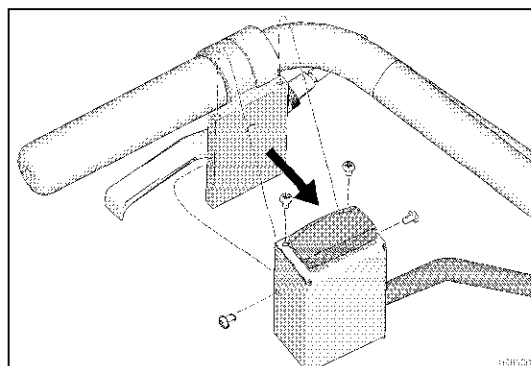

6. Unplug the wire harness from the switch and remove the drive switch from the housing.

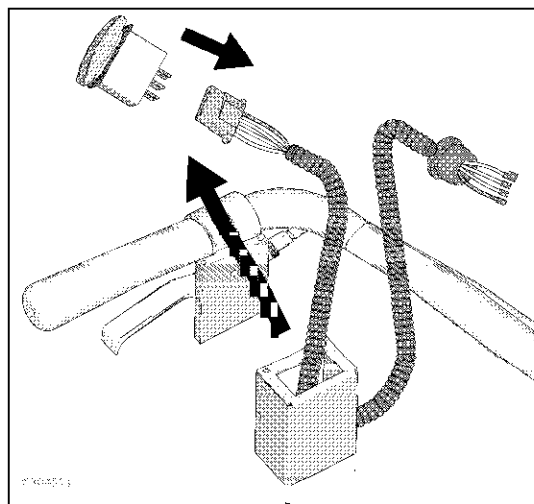

Installation

1. Install the switch into the housing and connect the wire harness to the switch.

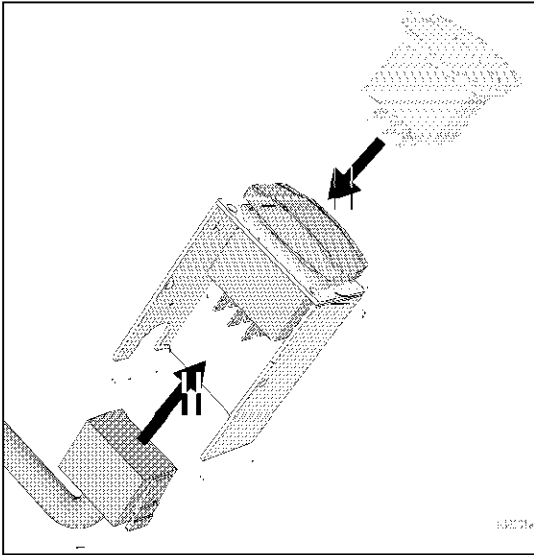

2. Install the four screws to attach the switch and switch housing to the mount.

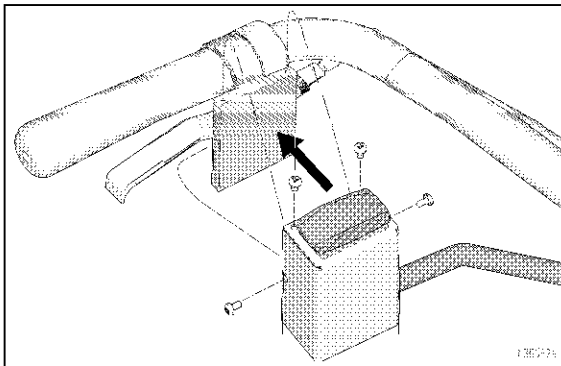

3. Connect blue and white wires to the control board (324), motor and speed control.

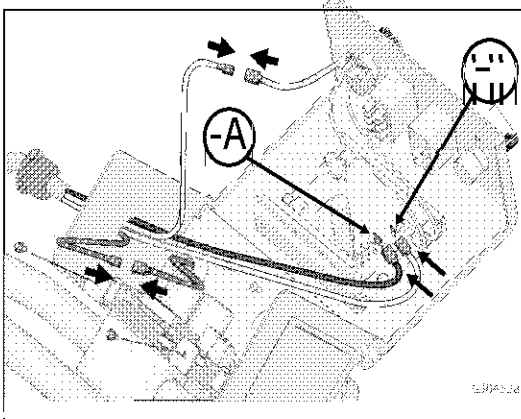

4. Replace the strain relief bushing (333) and close control box cover (62a).

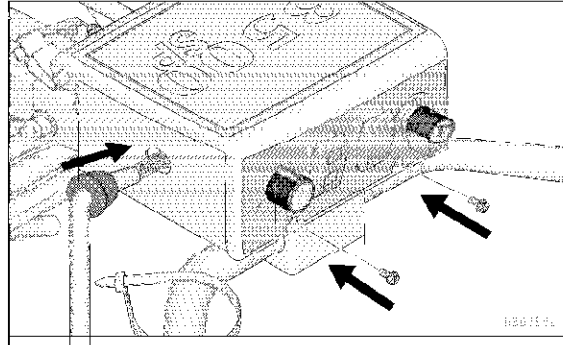

5. With the self-propelled drive system switch in the OFF position, and the drive switch in "N", connect the battery or insert the fuse.

NOTICE
DO NOT reverse the positive and negative battery wires. This will damage the motor control board.

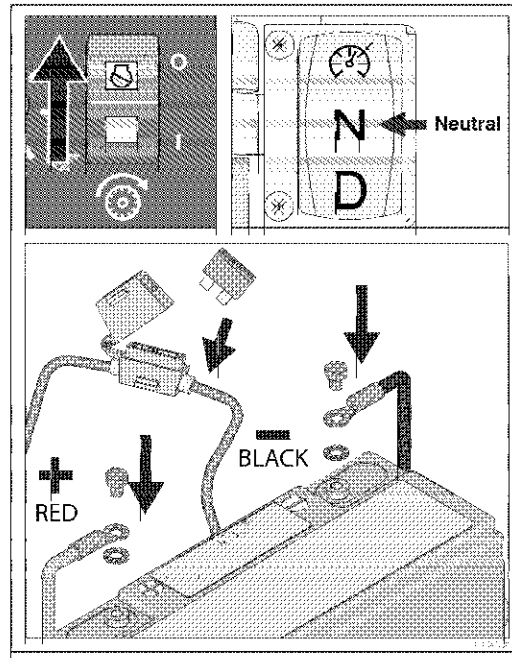

Drive/Axle Bearings

Removal

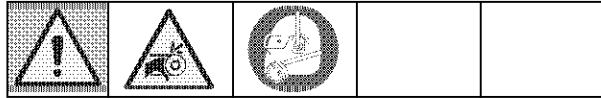

1. Shut off the engine and turn off the self-propelled drive system and switch to neutral.

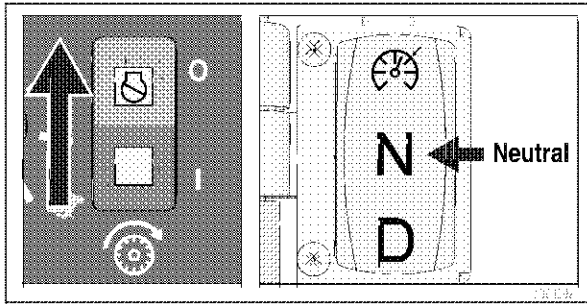

2. Remove bucket or hopper and securely elevate the rear of the striper.

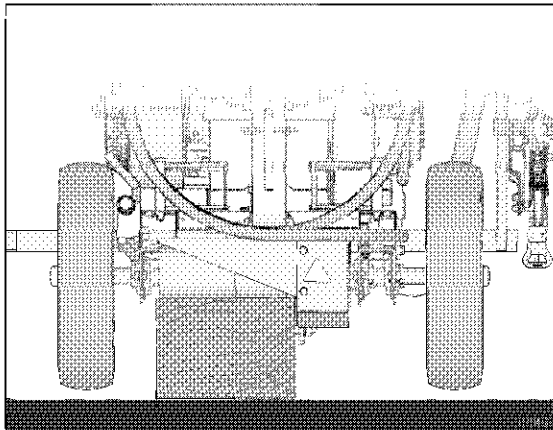

3. While holding the wheel (3) to keep the axle (300) from spinning, loosen and remove the axle nut (307). Slide the wheel off the axle making sure to retain the key (306).

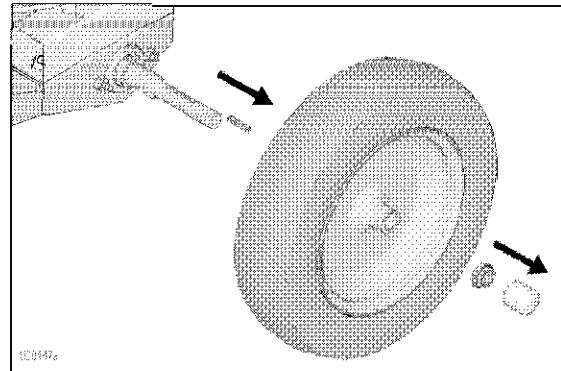

4. Remove the front (317) and rear (318) chain guards.

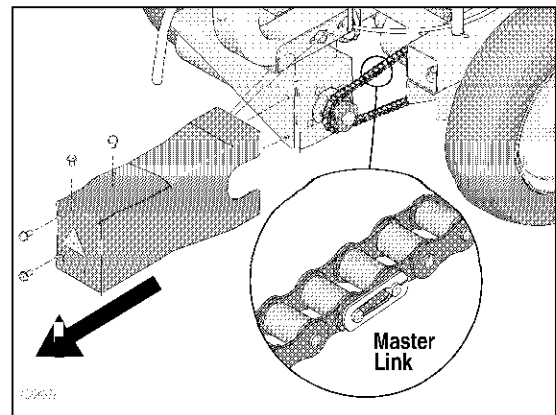

5. Disconnect the master link on the chain and remove the chain (316).

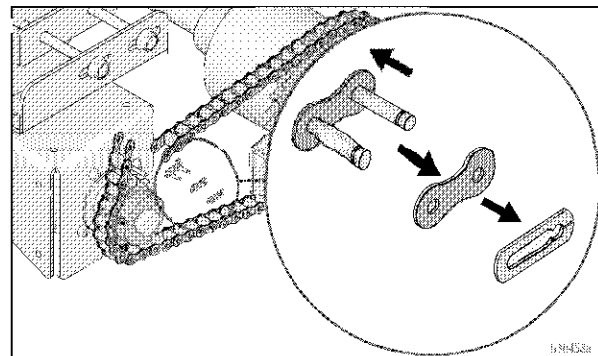

Drive/Axle Bearings

6. Remove the axle bracket nuts (309) and bolts (308) to disconnect the axle assembly from the stripper frame.

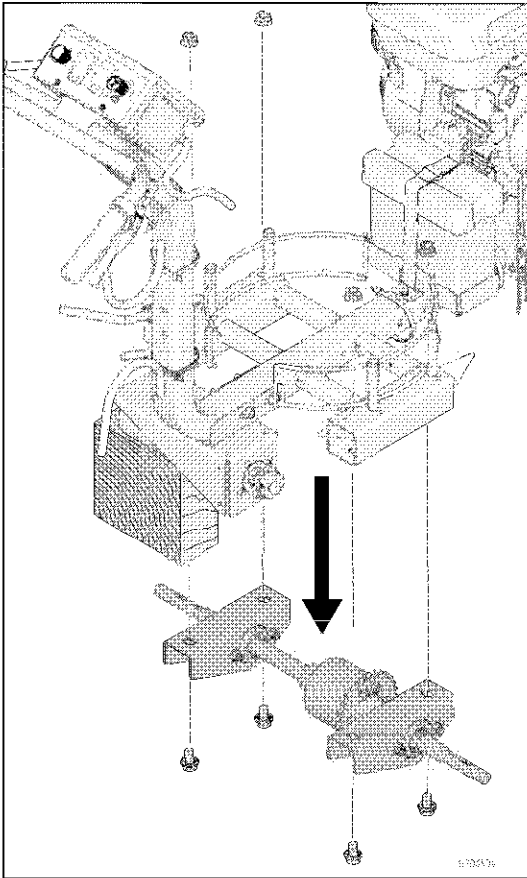

7. Loosen all of the bearing (303) set screws and slide each bracket-bearing assembly off of the axle (300).

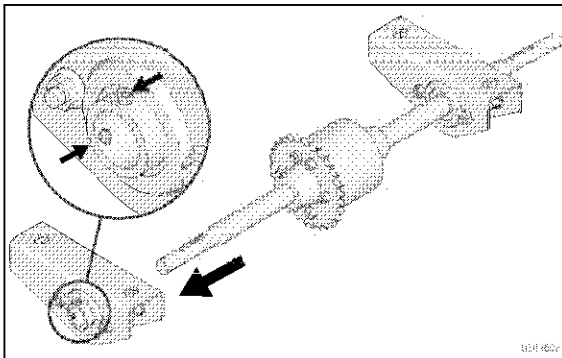

8. If replacing the axle bearings, unbolt each bearing (304 and 305) from the axle bracket (302).

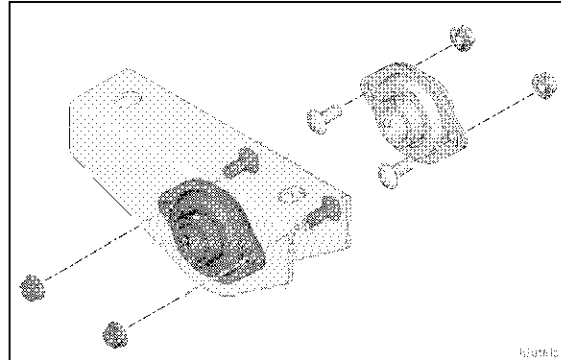

Installation

1. If replacing the axle bearings, bolt each bearing (303) to each axle bracket (302), and only hand tighten nuts (305).

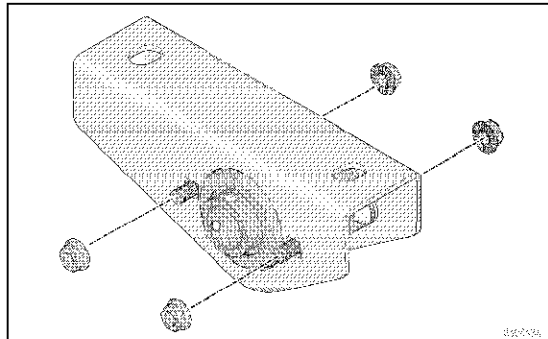

2. Slide each bracket-bearing assembly onto the axle, but do not tighten the bearing set screws.

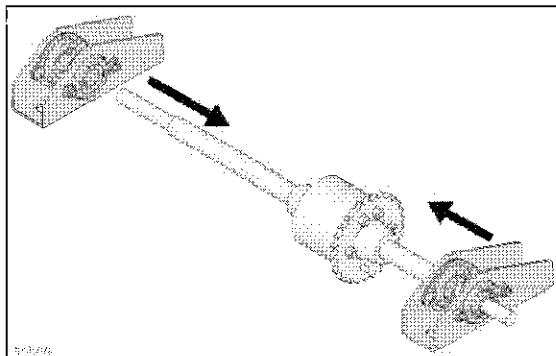

3. Bolt the axle assembly to the frame and torque to 30-40 ft-lb (40.7-54.2 N·m).

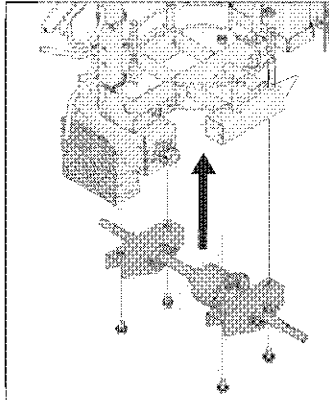

4. If bearings were replaced, torque the nuts (305) and bolts (304) to 23-27 ft-lb (31.2-36.6 N·m).

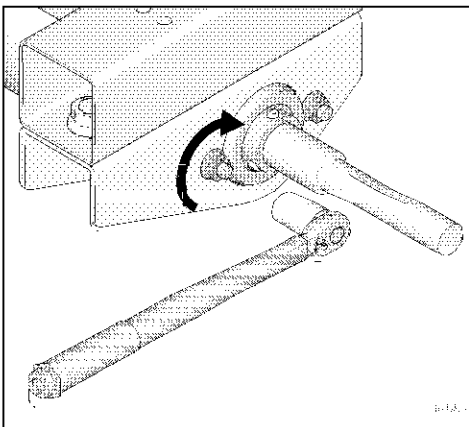

5. Align the axle sprocket with the motor sprocket, place a drop of blue thread locking liquid on each bearing set screw and tighten all set screws.

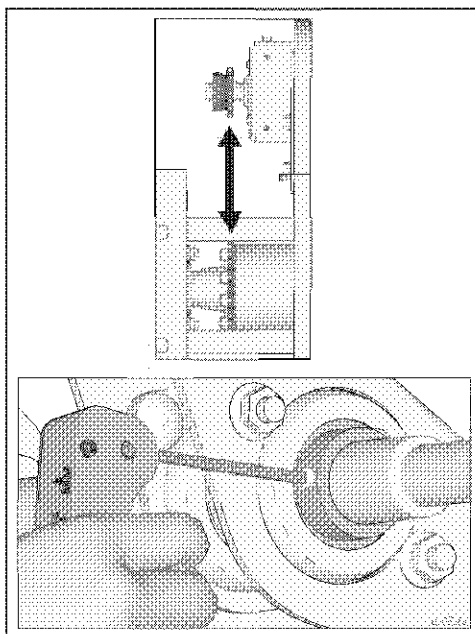

6. Wrap the chain (316) around the axle and motor sprockets and reconnect using the master link. Slight repositioning of the motor may be required.

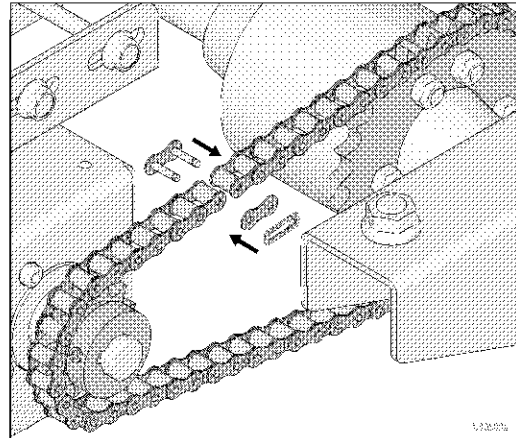

7. With the key (306) inserted into the axle keyway, slide each wheel (3) back onto the axle and secure using the axle nuts (307) and torque to 17-23 ft-lb (23-31 N·m). Replace the axle nut cap (131).

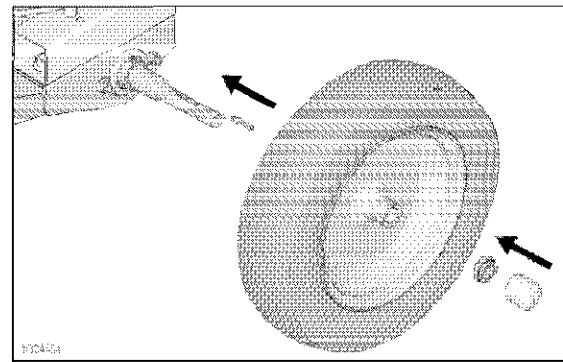

8. Install the front (317) and rear (318) chain guards and lower the striper back to the ground.

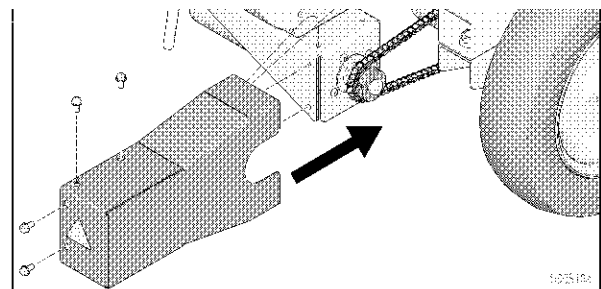

9. Place the bucket or hopper back onto the striper.

Drive Chain

Removal

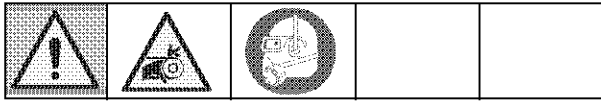

1. Shut off the engine, turn off the self-propelled drive system, switch to neutral and engage parking brake.

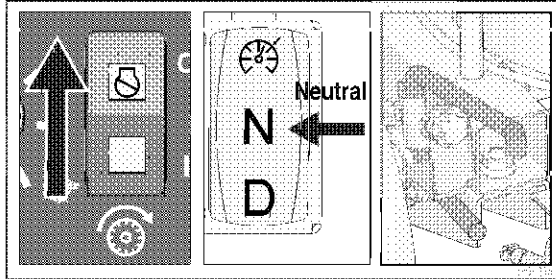

2. Remove the rear chain guard (318). Then rotate the wheel to position the master link as shown.

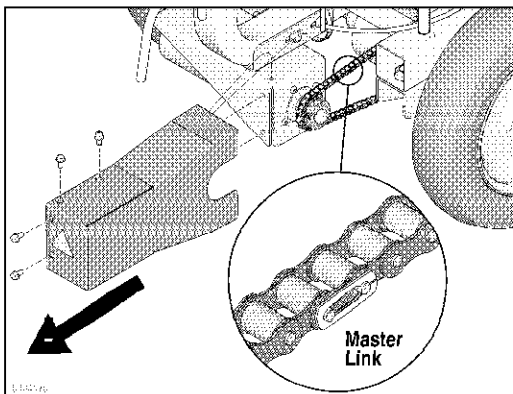

3. Disconnect the master link on the chain and remove the chain (316).

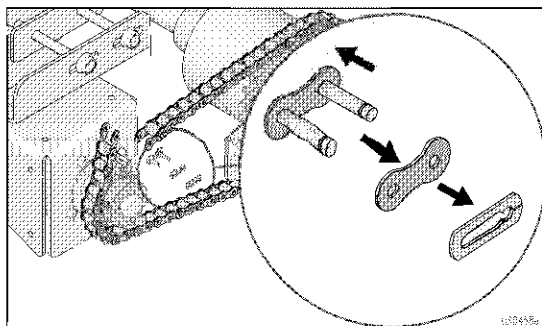

Installation

1. Wrap the chain around the axle and motor sprocket and reconnect using the master link.

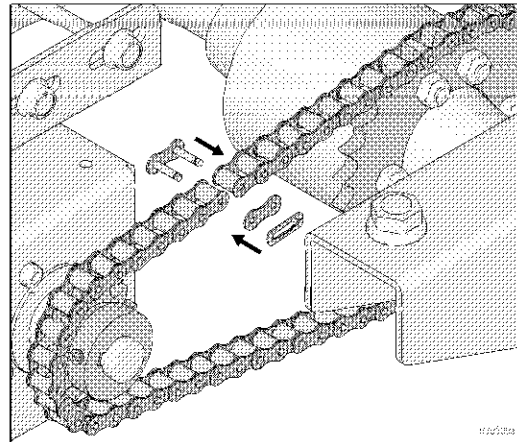

2. If the chain cannot be connected, or the chain slack needs adjusting, loosen the two motor bracket bolts (314) and slide the motor forward or backward as needed. Re-torque to 30-40 ft-lb (41-54 N·m).

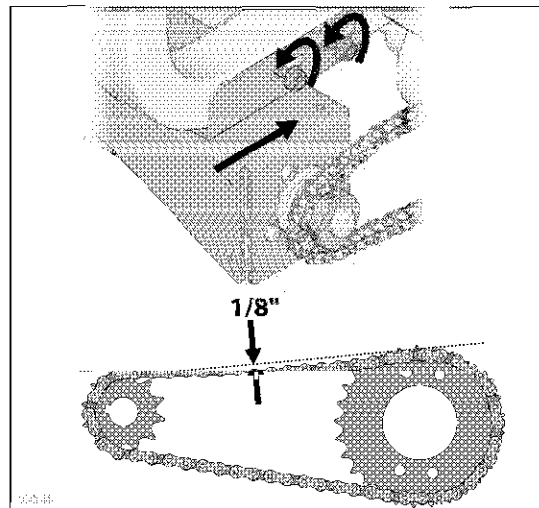

3. Install the rear chain guard (318).

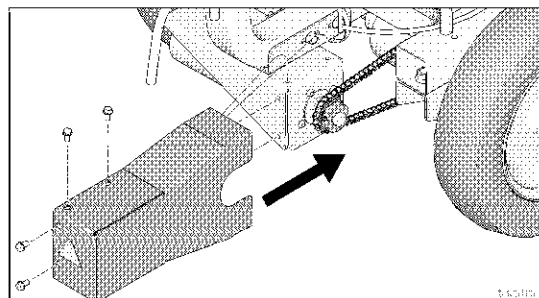

Motor Control Board

Removal

1. Shut off engine, turn off self-propelled drive system, switch to neutral and engage parking brake.

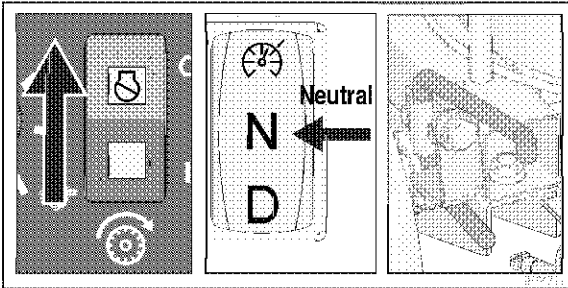

2. Remove the 30 amp fuse from the fuse holder near the battery.

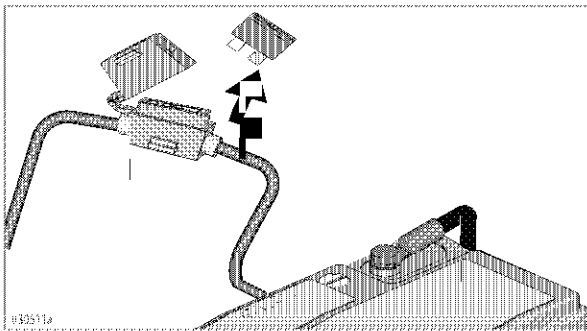

3. Open the control box cover (62a) and carefully disconnect the seven wires that are connected to the male spade terminals and the one white potentiometer wire.

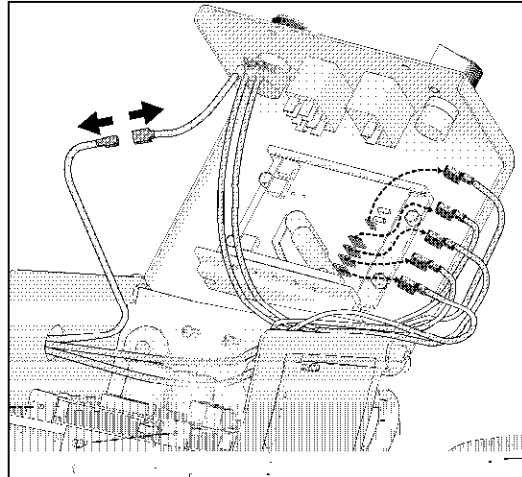

4. Unscrew the 4 mounting nuts (62f) and remove the control board (62e) from the control box cover (62a).

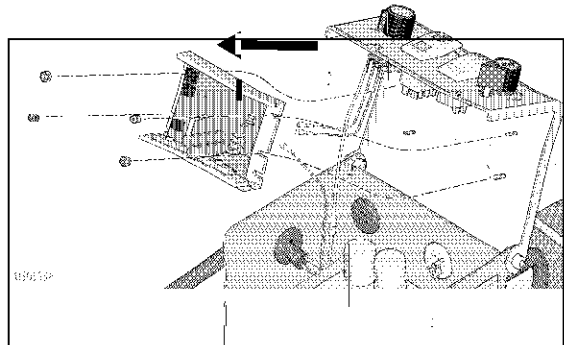

Installation

1. Locate control board (62e) on the four threaded studs in control box cover (62a) and secure using four mounting nuts (62f) torqued to 16-20 in-lb (1.8-2.3 N·m).

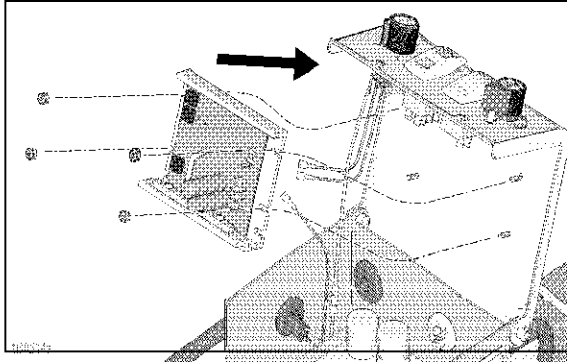

2. Connect the eight wires as shown (as indicated per the wire labels).

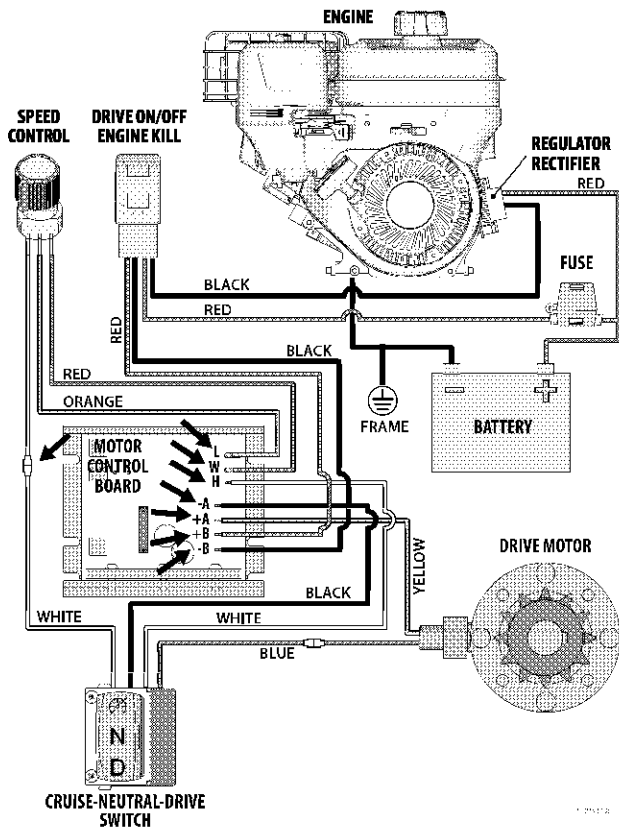

NOTICE

DO NOT reverse the positive and negative battery wires. This will damage the motor control board.

3. Close the control box cover (62a), ensure the drive power switch (62m) is in the OFF position, and reinsert the 30 amp fuse.

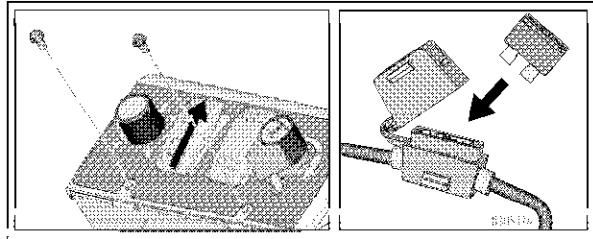

Speed Control

Removal

1. Shut off engine, turn off self-propelled drive system, switch to neutral and engage parking brake.

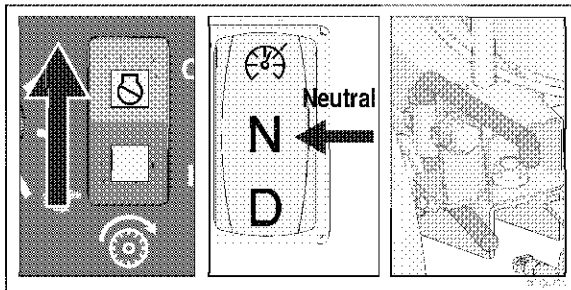

2. Open control box cover (62a) and carefully disconnect three wires.

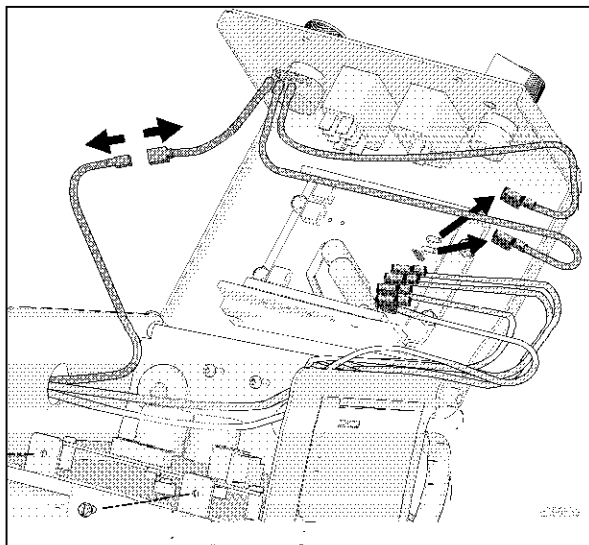

3. Remove the speed knob (62h) using a 5/64" allen wrench, the friction o-ring (62k), the retaining nut, and the spacer (62g).

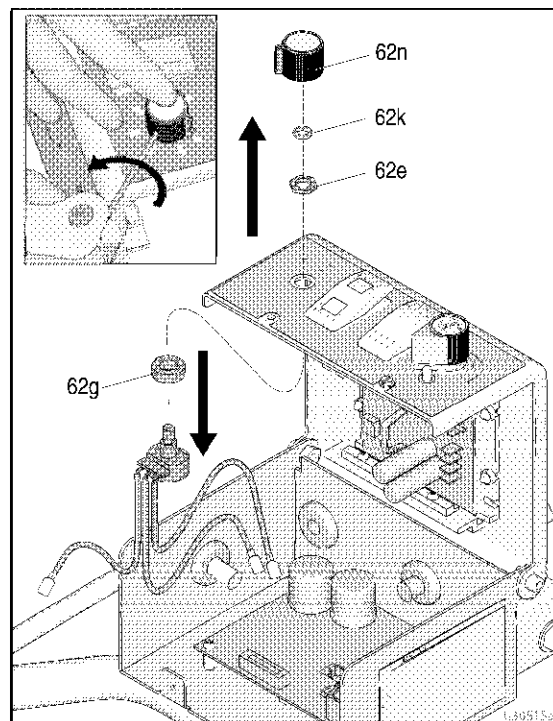

Installation

1. Slide the rubber spacer (62g) onto the speed potentiometer, insert the potentiometer into the hole in the cover (62a), and secure using the retaining nut torqued to 8-11 in-lb (0.9-1.2 N·m), then slide the friction o-ring (62k) onto the stud.
2. Turn the potentiometer stud completely counter-clockwise, then place the speed knob (62n) onto the stud. With the indicator aligned with the first tick mark, and while pressing down on the knob, tighten the two setscrews so the knob does not spin on the stud.

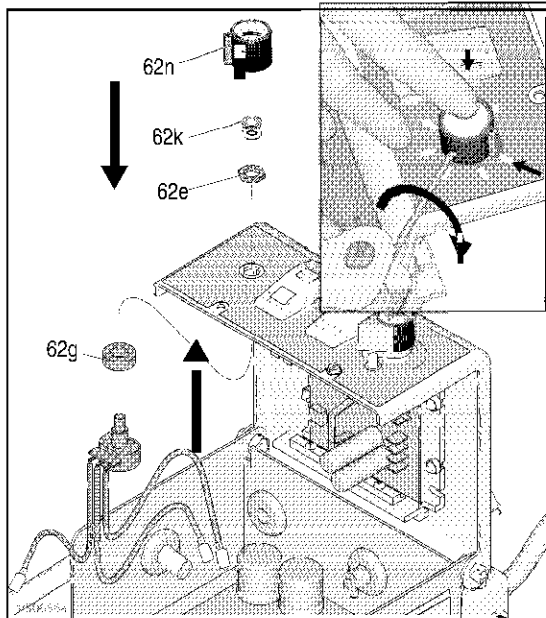

3. Reconnect the three speed control wires. White to the other white wire, orange to "LO," and red to "WP".

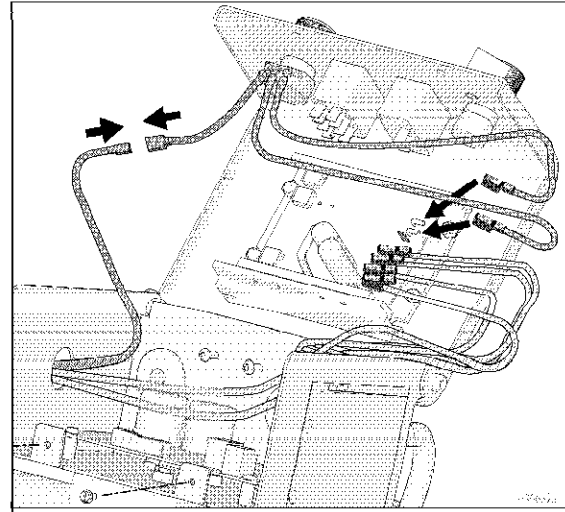

4. Close the control box cover (62a).

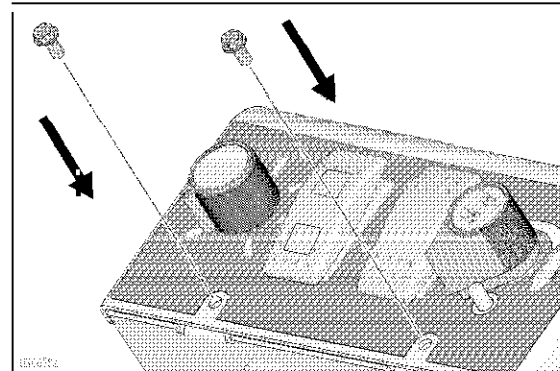

Drive System

Does not Drive

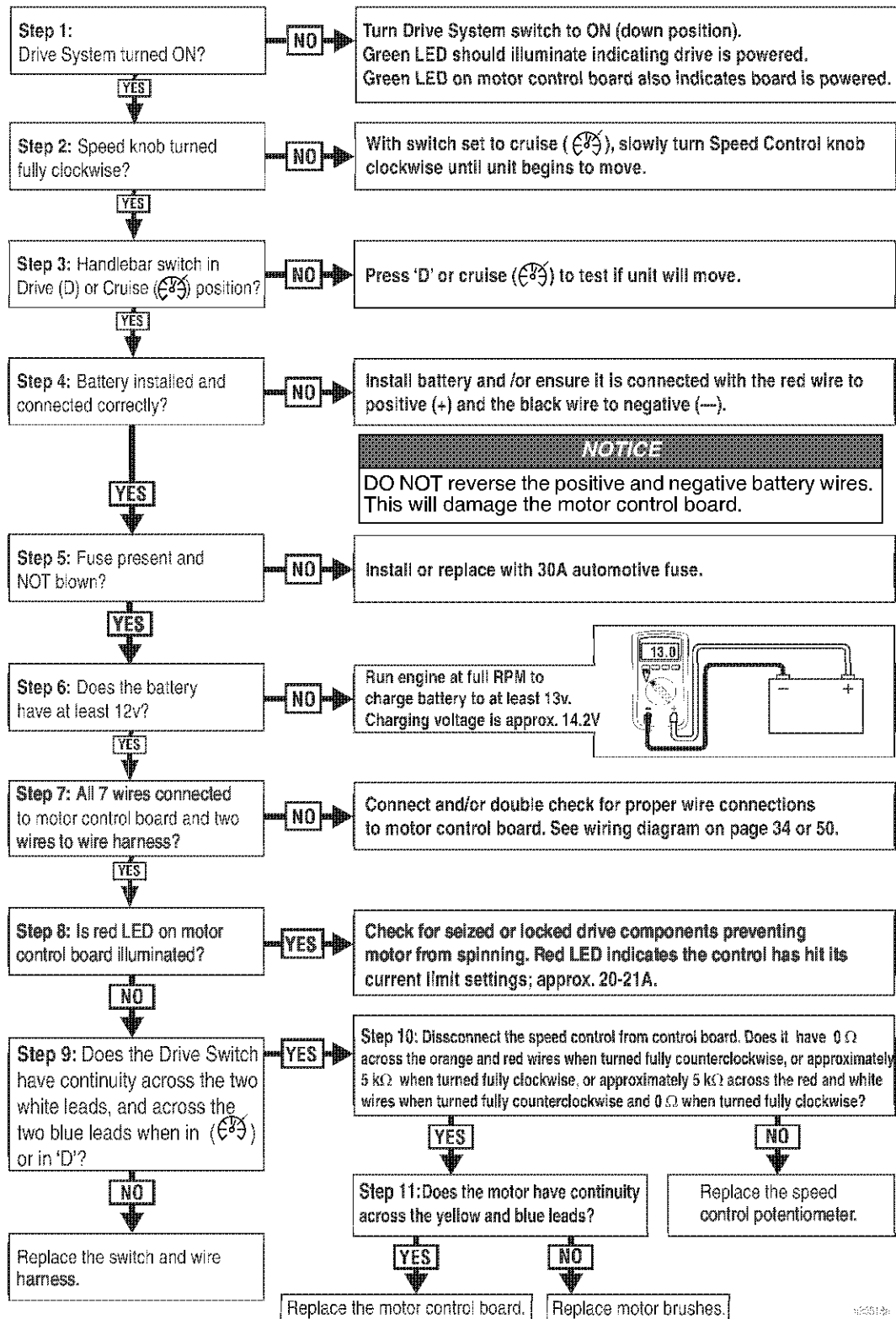

Fluid Pump Runs Constantly

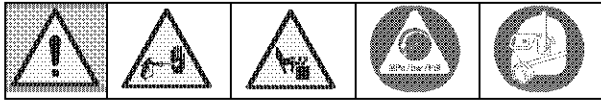

1. Perform **Pressure Relief Procedure**, page 6, turn prime valve forward to SPRAY position, and turn power switch OFF.
2. Remove control box cover.

Troubleshooting Procedure:

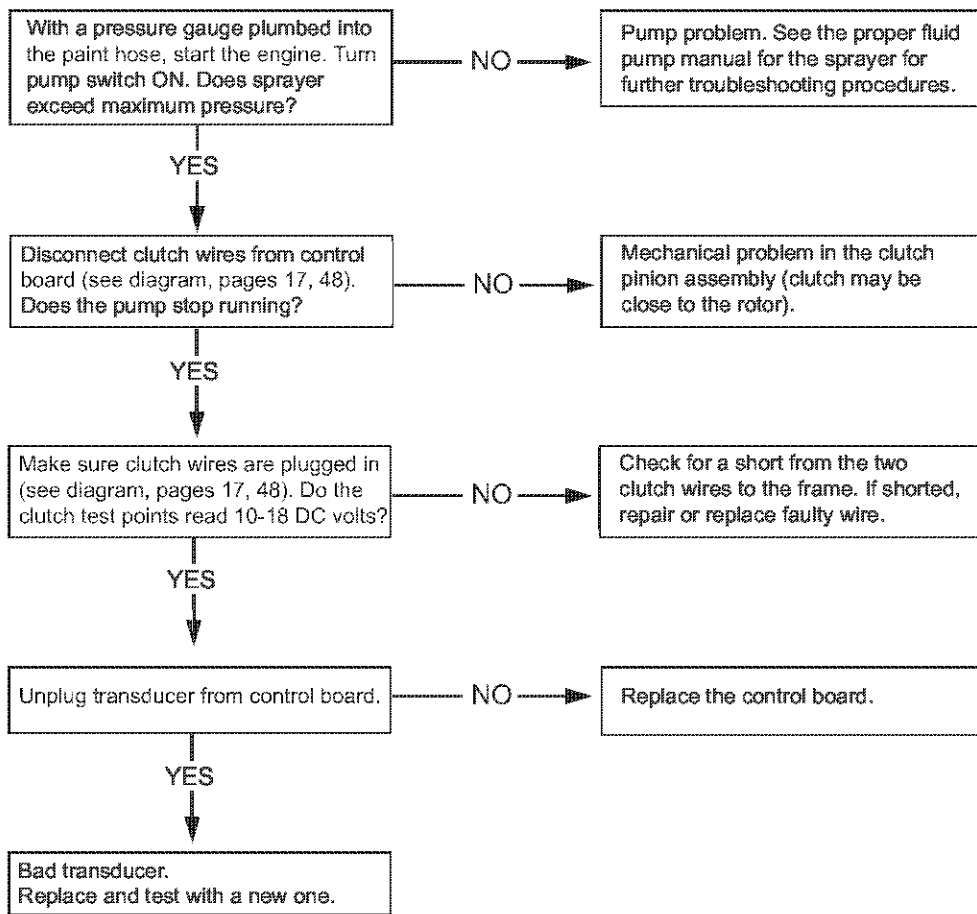

t129061a

Control Board Malfunction

Troubleshooting Procedure
 (see following page for actual steps):

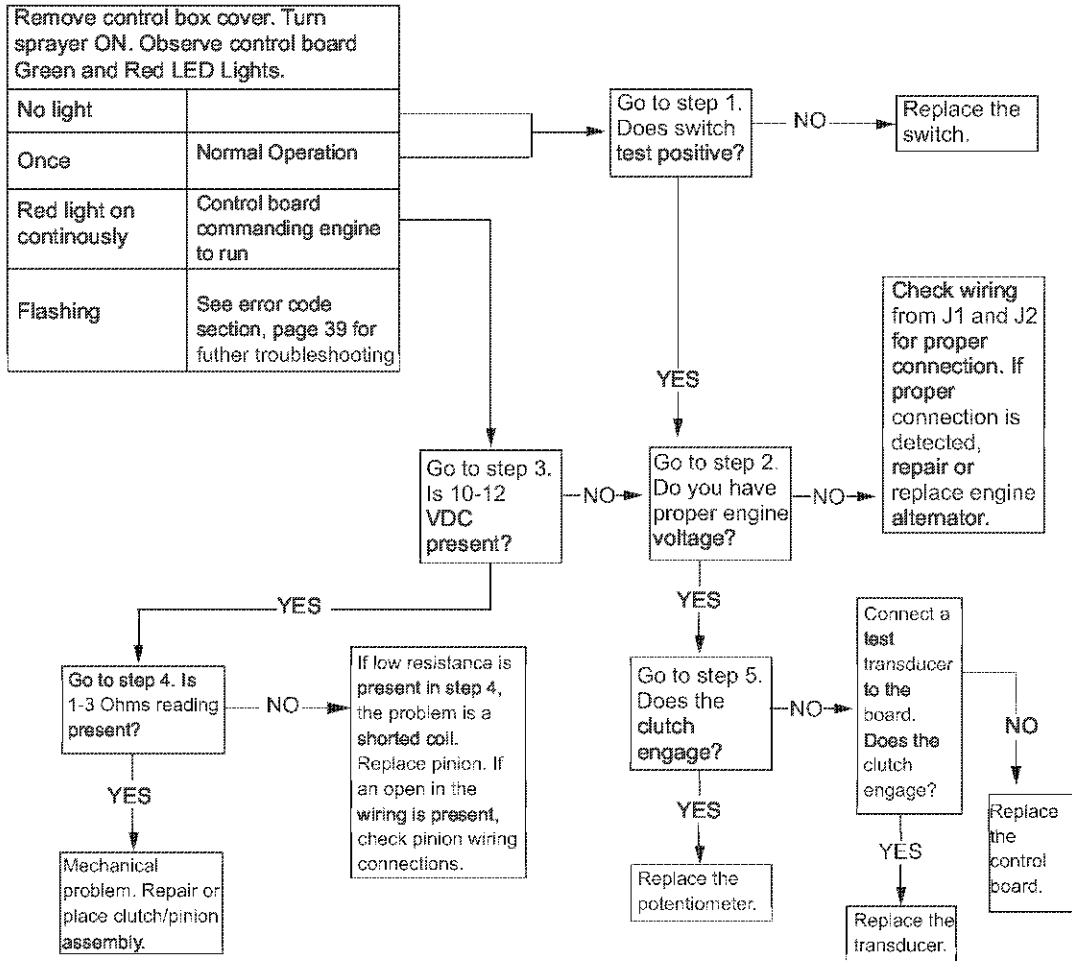

ti29062a

Control Board Malfunction (Steps)

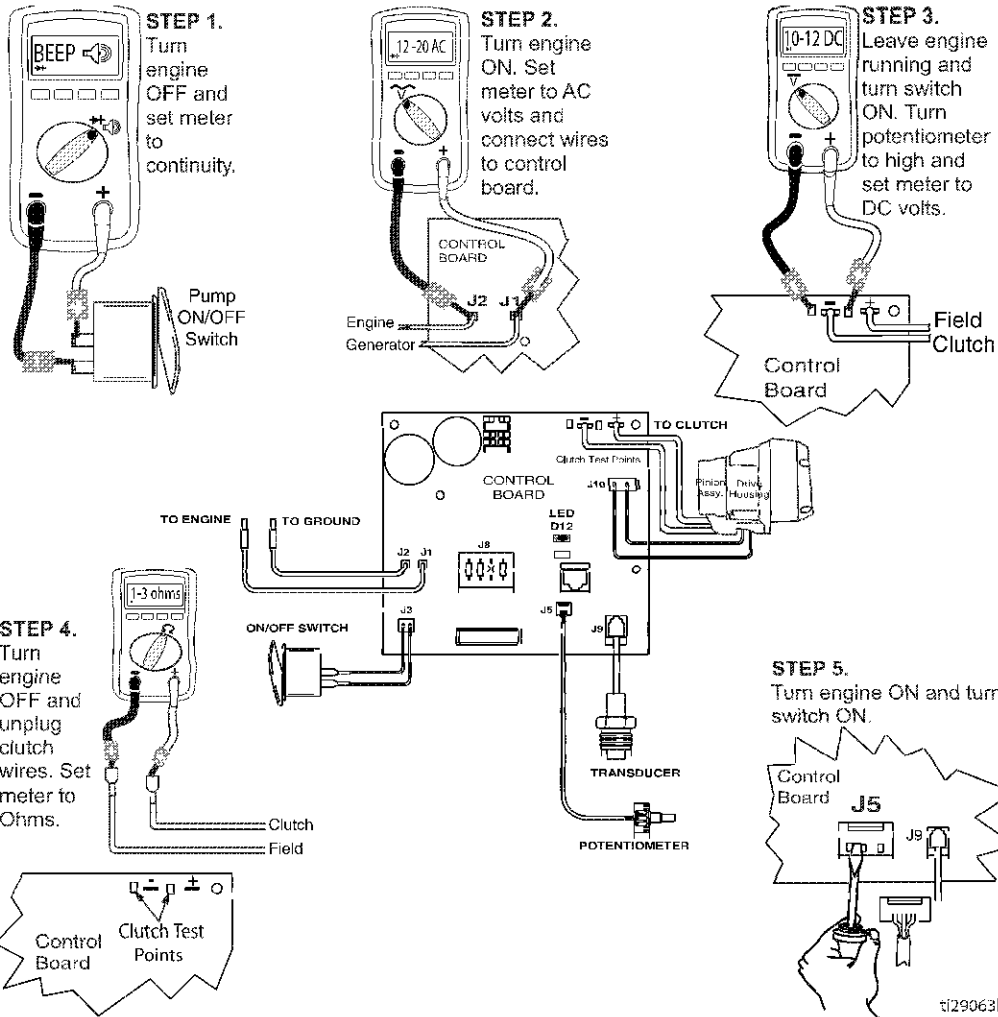

ti29063b

Digital Display Messages

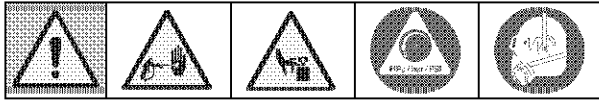

| LED Status | SPRAYER OPERATION | INDICATION | ACTION |
|--------------------------------|---|--|---|
| Red LED 1 blink at power up | Power is applied. (Pressure varies with tip size and pressure control setting). | Normal operation. | Spray |
| Red LED ON continuous | Sprayer won't run. | Pump won't cycle. | Ensure there is no resistor at J8/2 near the center of the pump control board. |
| Red LED 2 blinks continuous | Sprayer stops. Engine is running. | Exceeded pressure limit. | <ol style="list-style-type: none"> 1. Check fluid path for clogs, such as clogged filter. 2. Open prime valve and gun if running AutoClean. 3. Use Graco paint hose, 1/4 in. x 50 ft minimum. Smaller hose or metal braid hose may result in pressure spikes. 4. Replace transducer if fluid path is not clogged and proper hose is used. |
| Red LED 3 blinks continuous | Sprayer stops. Engine is running. | Pressure transducer faulty, bad connection or broken wire. | <ol style="list-style-type: none"> 1. Check transducer connection. 2. Disconnect and reconnect transducer plug to ensure good connection with control board socket. 3. Open prime valve. Replace sprayer transducer with known good transducer and run sprayer. Replace transducer if sprayer runs or control board if sprayer does not run. |
| Green LED ON continuous | Sprayer stops. Engine is running. | Loss of paint to pump or severe pressure loss. | <ol style="list-style-type: none"> 1. Check for empty paint condition, clogged inlet strainer, failed pump or severe leak. 2. Reduce pressure and turn pump switch OFF and ON to restart pump. |

Parts Drawing

25M230

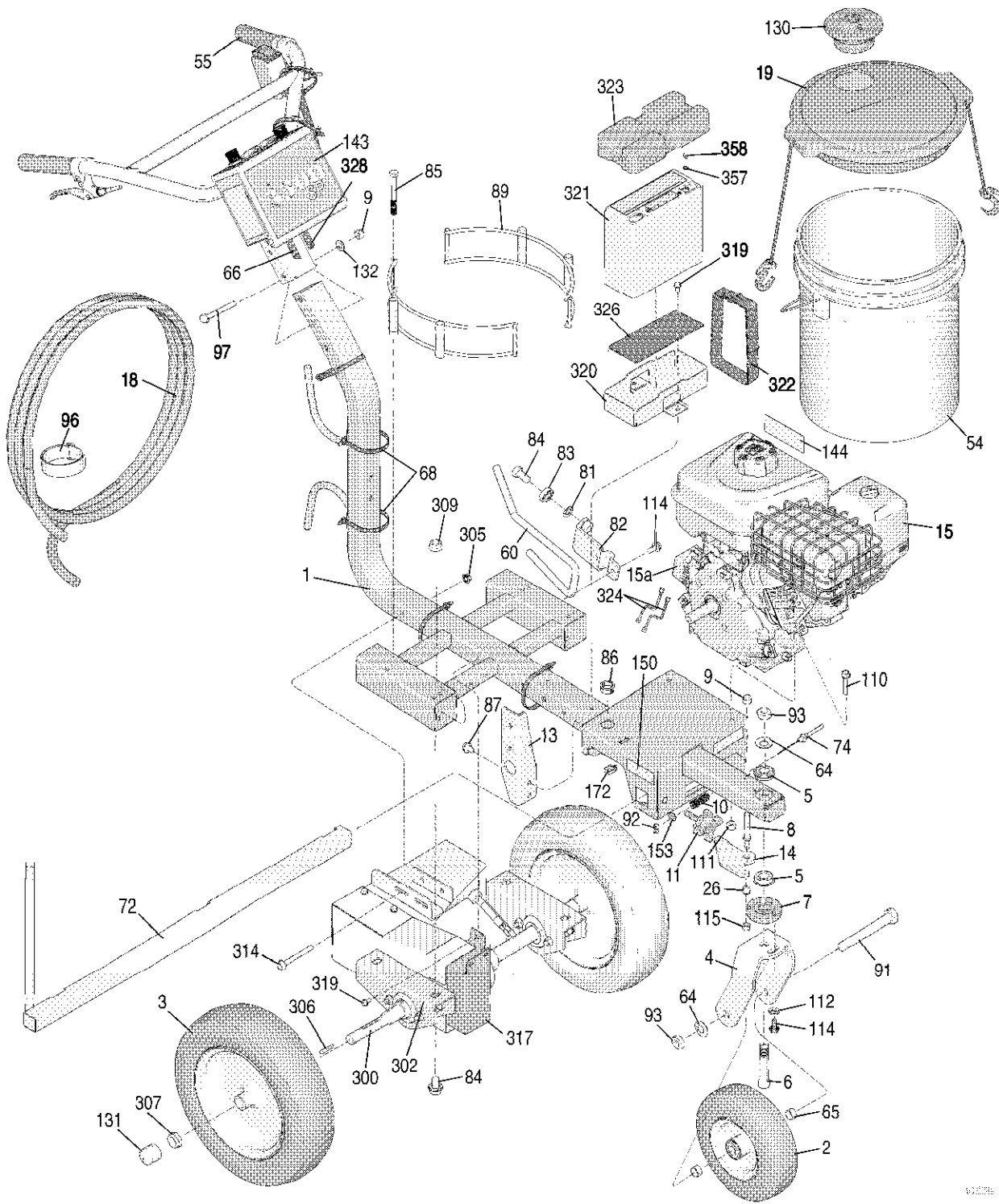

Parts List - 25M230

| Ref. | Part | Description | Qty | Ref. | Part | Description | Qty |
|------|--------|--|-----|---------|--|---|-----|
| 1 | 17N512 | FRAME | 1 | 92 | 114802 | WIRE, stop | 1 |
| 2 | 119542 | WHEEL, small | 1 | 93 | 119554 | NUT, lock, nylon, thin pattern | 2 |
| 3 | 17N070 | WHEEL, large | 2 | 96 | 129382 | STRAP, hose wrap | 1 |
| 4 | 17N149 | FORK, painted | 1 | 97 | 116935 | SCREW, cap, flng hd | 2 |
| 5 | 119532 | BEARING, flanged | 2 | 110 | 110837 | SCREW, flange, hex | 2 |
| 6 | 15E780 | PIN, fork | 1 | 111 | 110838 | NUT, lock | 2 |
| 7 | 15E773 | DISK, adjuster | 1 | 112 | 122669 | WASHER, flat, extra thick | 1 |
| 8 | 15E792 | PIN, lever | 1 | 114 | 110963 | SCREW, cap, flng hd | 3 |
| 9 | 101566 | NUT, lock | 3 | 115 | 111040 | NUT, lock, insert, nylock, 5/16 in. | 1 |
| 10 | 114682 | SPRING, compression | 1 | 130 | 278723 | GASKET, pail | 1 |
| 11 | 108471 | KNOB, pronged | 1 | 131 | 17P224 | CAP, leg | 2 |
| 13 | 15E748 | BRACKET, manifold | 1 | 132 | 100731 | WASHER | 2 |
| 14 | 287682 | LEVER, caster, includes 26 | 1 | 143 | 17N701 | LABEL, BS 3500SP | 1 |
| 15 | 17N210 | ENGINE, gasoline, 5.5 hp | 1 | 144▲ | 194126 | LABEL, warning | 1 |
| 15a | 129777 | REGULATOR | 1 | 150▲ | 16P136 | LABEL, safety, warning | 1 |
| 16 | 867670 | FLUID, TSO, 6 oz. (not shown) | 1 | 153 | 111025 | GASKET, polypropylene | 1 |
| 18 | 17M383 | HOSE, coupled, 1/4 in. x 50 ft, nickel | 1 | 172 | 117727 | CLIP, wire | 1 |
| 19 | 24U241 | KIT, pail cover | 1 | 306 | 117632 | KEY, square, 3/16 | 2 |
| 26 | 111016 | BEARING, flange | 1 | 307 | 112405 | NUT, lock | 2 |
| 32 | 128978 | SCREW, 8-32 hex washer head | 6 | 319 | 107257 | SCREW, thd forming | 10 |
| 54 | 115077 | PAIL, plastic | 1 | 320 | 17N480 | HOLDER, battery | 1 |
| 55 | 129378 | GRIP, handle | 2 | 321 | 17P448 | BATTERY, 22Ah | 1 |
| 60 | 15E993 | ROD, brake | 1 | 322 | 126949 | STRAP, battery | 1 |
| 64 | 119563 | WASHER, belleville | 2 | 323 | 17N699 | COVER, battery | 1 |
| 65 | 15E996 | SPACER, wheel | 2 | 324 | 129421 | ADAPTER, jumper | 2 |
| 66 | 15E995 | HARNESS, wiring, control | 1 | 326 | 129529 | PAD, battery | 1 |
| 68 | 404984 | STRAP, tie | 11 | 328 | 17N239 | HARNESS, wire, drive power | 1 |
| 72 | 224052 | BRACKET, support, gun | 1 | 357 | 111307 | WASHER, lock, external | 2 |
| 74 | 241445 | CABLE, caster | 1 | 358 | 128131 | SCREW, cap, hex, M5 x 6 mm | 2 |
| 81 | 195134 | SPACER, ball, guide | 1 | 382 | 865714 | SOLVENT, pump conditioner, 1 qt. (not shown) | 1 |
| 82 | 198891 | BRACKET, mounting | 1 | ▲222385 | LABEL, warning, medical alert (not shown) | 1 | |
| 83 | 198931 | BEARING | 1 | | | | |
| 84 | 113961 | SCREW, cap, hex hd | 1 | | | | |
| 85 | 867517 | SCREW, hex head, 3/8-16 x 3.5" | 4 | | | | |
| 86 | 129528 | GROMMET, split, 1" hole | 1 | | | | |
| 87 | 111801 | SCREW, cap, hex, hd | 4 | | | | |
| 89 | 17N536 | HOLDER, bucket | 2 | | | | |
| 91 | 113665 | SCREW, cap, hex hd | 1 | | | | |

▲ Replacement Danger and Warning labels, tags, and cards are available at no cost.

Parts Drawing

Self-Propelled Drive

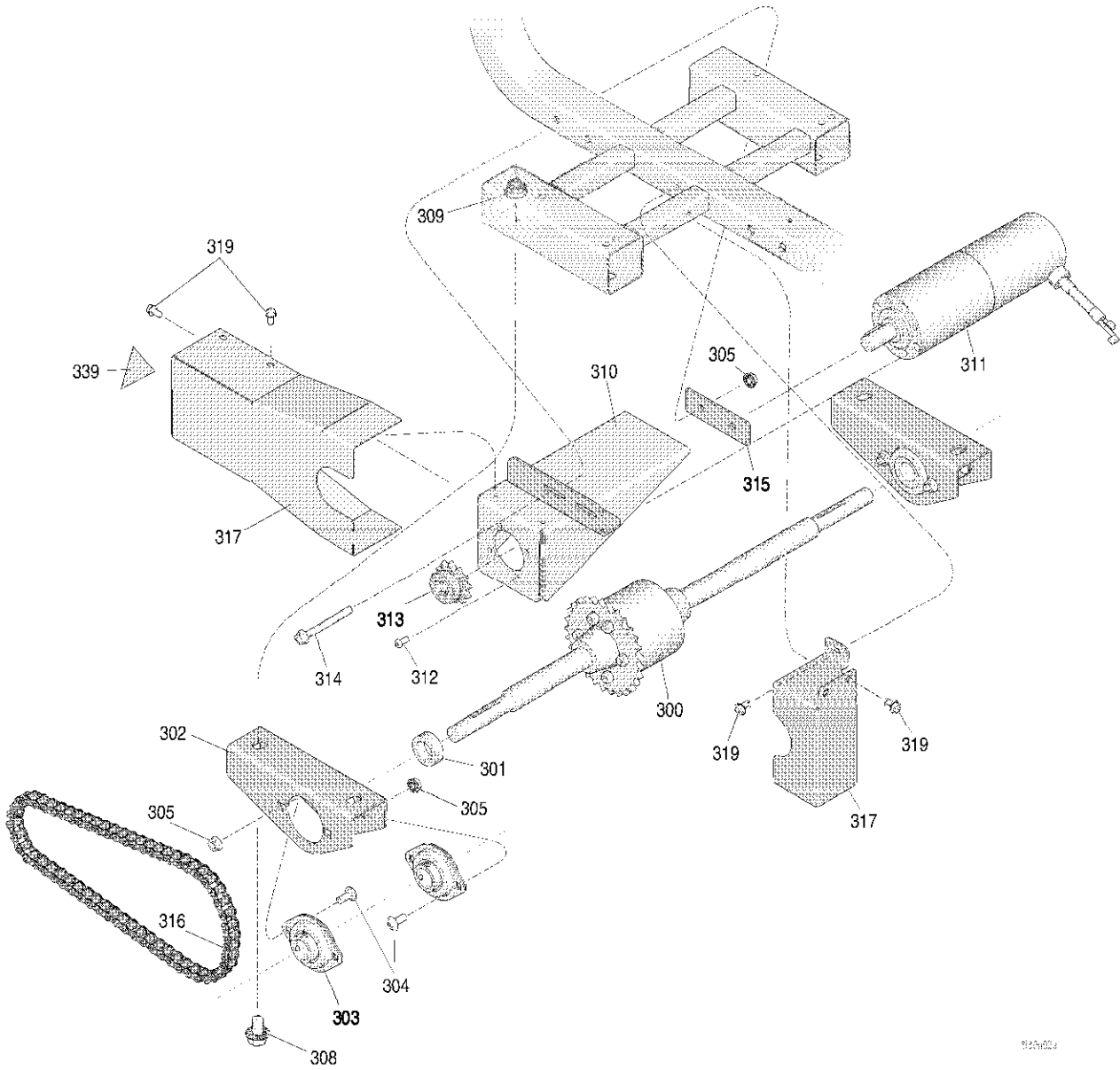

Parts List - Self-Propelled Drive

| Ref. | Part | Description | Qty | Ref. | Part | Description | Qty |
|------|--------|-------------------------|-----|------|--------|----------------------------------|-----|
| 300 | 17N475 | AXLE, self-propelled | 1 | 313 | 129467 | SPROCKET, 12 tooth | 1 |
| 301 | 17N316 | SPACER, unthreaded | 1 | 314 | 120229 | SCREW, hex, flange | 2 |
| 302 | 17N662 | BRACKET, axle | 2 | 315 | 17P355 | BRACE, motor bracket, painted | 1 |
| 303 | 129437 | BEARING, flange, 2 bolt | 4 | 316 | 129466 | CHAIN, roller, #40 | 1 |
| 304 | 129465 | BOLT, carriage | 8 | 317 | 17P356 | BRACKET, chain guard | 1 |
| 305 | 110996 | NUT, hex, flange | 10 | 318 | 17P357 | GUARD, chain, painted | 1 |
| 308 | 111802 | SCREW, cap, hex hd | 4 | 339▲ | 16M768 | LABEL, safety, warning, entangle | 1 |
| 309 | 112731 | NUT, hex, flanged | 4 | | | | |
| 310 | 17P354 | BRACKET, motor | 1 | | | | |
| 311 | 17N311 | MOTOR, 12V DC gear | 1 | | | | |
| 312 | 121518 | SCREW, cap, shc | 4 | | | | |

▲ Replacement Danger and Warning labels, tags, and cards are available at no cost.

Parts Drawing

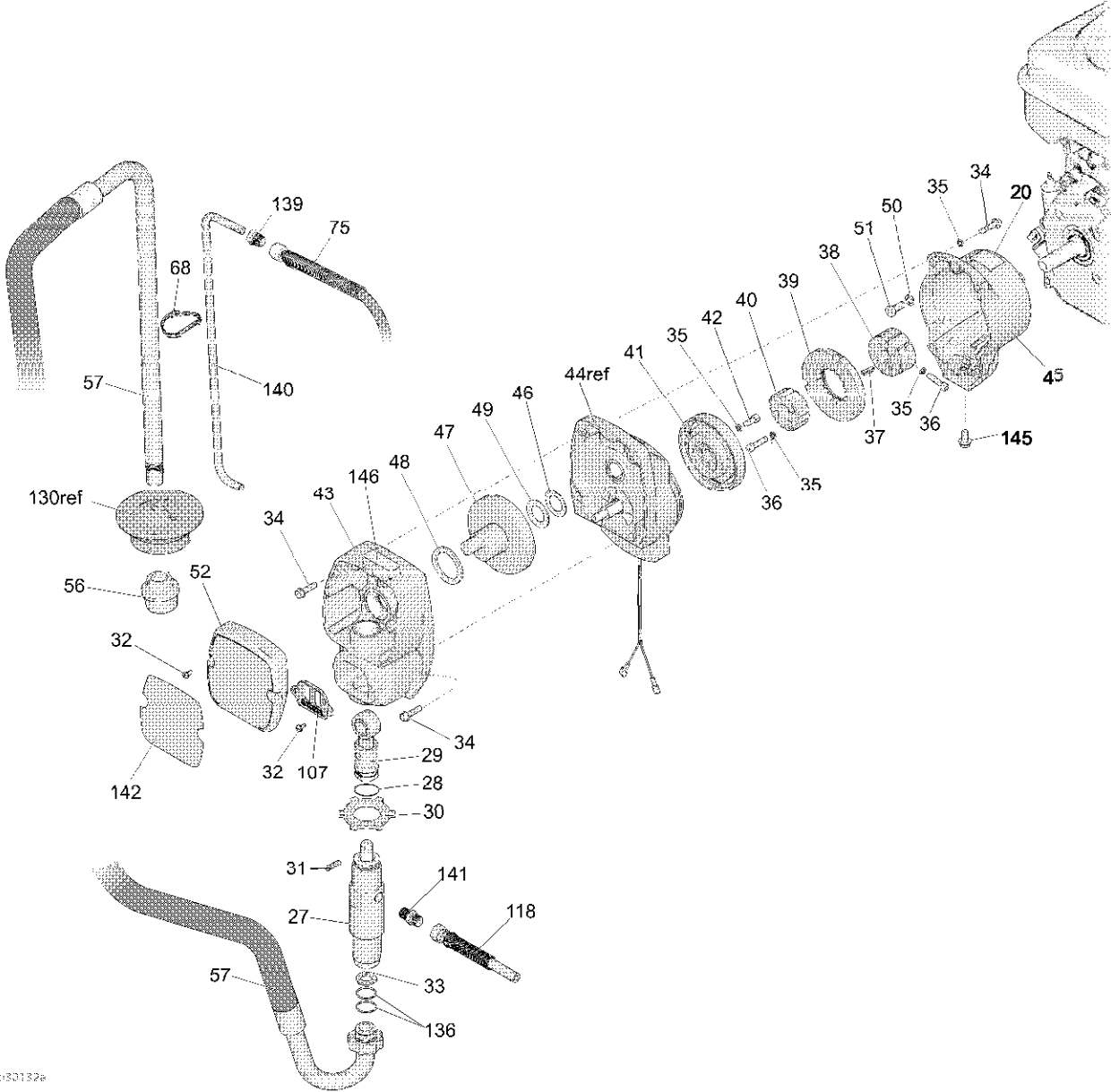

6/20132e

Parts List - 25M230

| Ref. | Part | Description | Qty | Ref. | Part | Description | Qty |
|------|--------|----------------------------------|-----|------|--------|---|-----|
| 20 | 16D576 | LABEL, made in USA | 1 | 49 | 107434 | BEARING, thrust | 1 |
| 27 | 17M989 | PUMP, displacement | 1 | 50 | 100214 | WASHER, lock | 4 |
| 28 | 196750 | SPRING, retaining | 1 | 51 | 108842 | SCREW, cap, hex hd | 4 |
| 29 | 287053 | ROD, connecting | 1 | 52 | 277019 | COVER, front, includes 32 | 1 |
| 30 | 195150 | NUT, jam, pump | 1 | 56† | 246385 | STRAINER, 7/8-14 unf | 1 |
| 31 | 196762 | PIN, straight | 1 | 57 | 17P807 | HOSE, suction, includes 33, 56, 130, 136 | 1 |
| 32 | 128978 | SCREW, mach, hex washer head | 6 | 75† | 17M382 | HOSE, cpld, 1/4 in. X 4.5 ft | 1 |
| 33† | 115099 | WASHER | 1 | 107 | 15B589 | COVER, pump rod | 1 |
| 34 | 119426 | SCREW, mach, hex washer hd | 8 | 118 | 17M384 | HOSE, coupled, 1/4 in. X 22.25 in. | 1 |
| 35* | 105510 | WASHER, lock, spring (hi-collar) | 10 | 136† | 117559 | O-RING | 2 |
| 36* | 108803 | SCREW, hex, socket head | 6 | 139† | 196180 | BUSHING | 1 |
| 37 | 183401 | KEY, parallel | 1 | 140† | 16X071 | TUBE, drain | 1 |
| 38 | 193680 | COLLAR, shaft | 1 | 141 | 196181 | FITTING, nipple | 2 |
| 39* | 193673 | ARMATURE, clutch, 4 in. | 1 | 142 | 17N700 | LABEL, pump, BS 3500SP | 1 |
| 40* | | HUB, armature | 1 | 145 | 112395 | SCREW, cap, flng hd | 1 |
| 41* | | ROTOR, clutch, 4 in. | 1 | 146▲ | 290228 | LABEL, warning | 1 |
| 42* | 101682 | SCREW, cap, sch | 4 | | | | |
| 43 | 17M310 | HOUSING, drive, includes 32, 34 | 1 | | | | |
| 45 | 17M314 | HOUSING, clutch, machine | 1 | | | | |
| 46 | 116074 | WASHER, thrust | 1 | | | | |
| 47 | 287484 | CRANK, includes 46, 48, 49 | 1 | | | | |
| 48 | 180131 | BEARING, thrust | 1 | | | | |

▲ Replacement Danger and Warning labels, tags, and cards are available at no cost.

* Included in Clutch Replacement Kit 241109

† Included in Suction Hose Kit 17P807

Parts Drawing and List - Pinion Housing

Ref No. 44: Pinion Housing

| Ref. | Part | Description | Qty |
|------|--------|-----------------------|-----|
| 44 | 17R785 | HOUSING, pinion, kit | 1 |
| 44a | 17R793 | KIT, repair, coil | 1 |
| 44b | 105489 | PIN | 2 |
| 44c* | 17R788 | PINION SHAFT | 1 |
| 44d* | 113094 | RETAINING RING, large | 1 |
| 44e* | 165295 | O-RING, packing | 1 |

* May be ordered separately

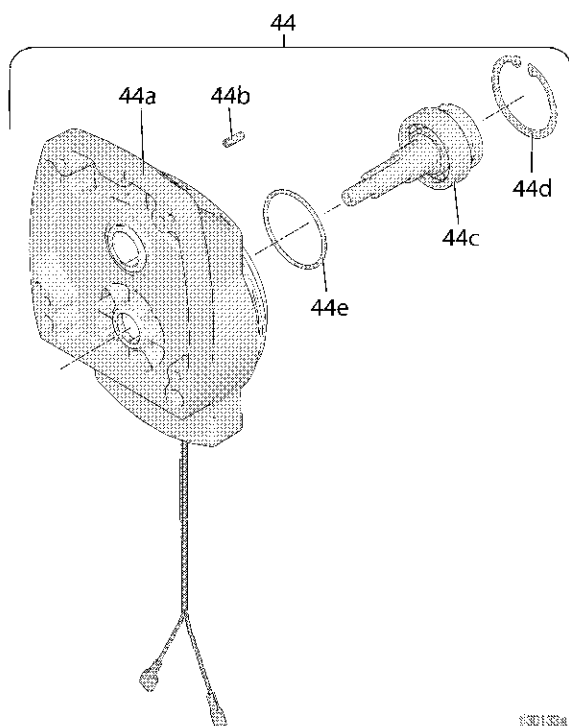

Gun Arm Parts

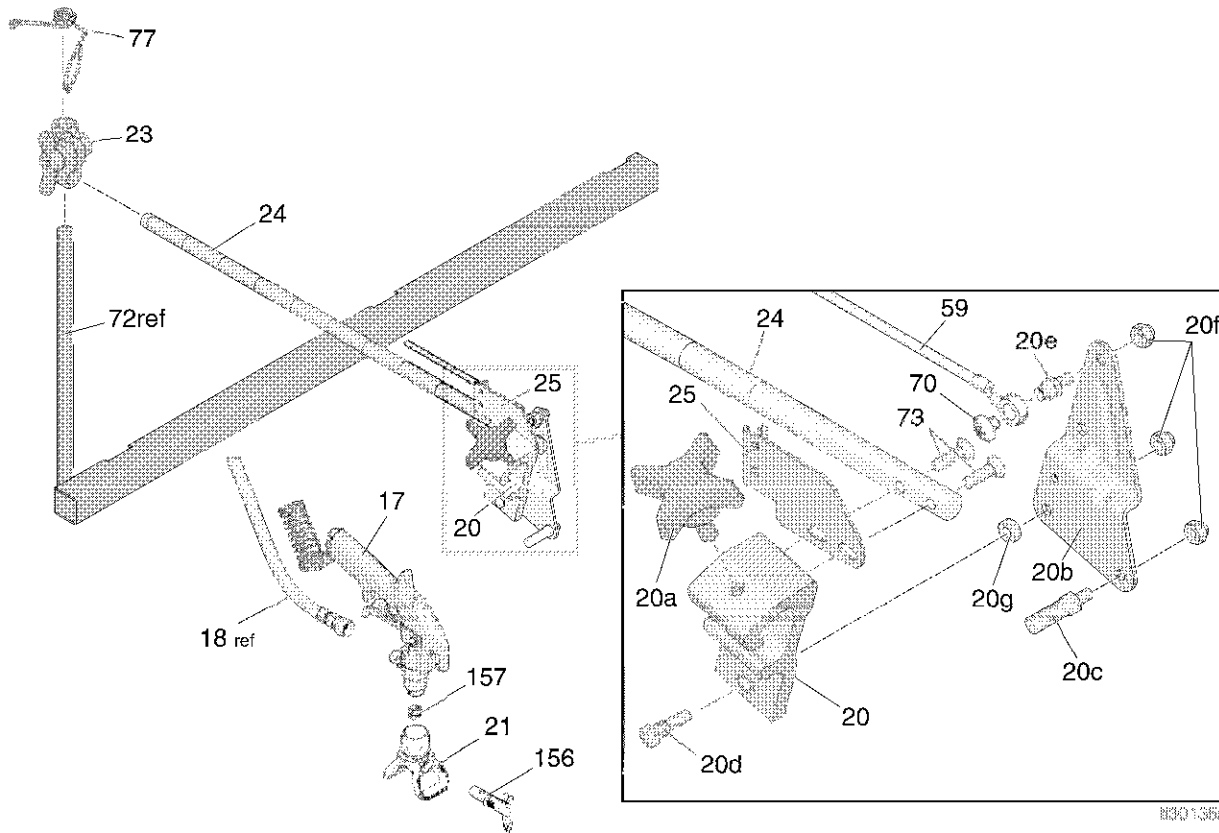

| Ref | Part | Description | Qty | Ref | Part | Description | Qty |
|------|--------|--------------------|-----|-------|---------|-----------------------------------|-----|
| 17 | 25M223 | GUN, SureStripe | 1 | 59 | 15E992 | CABLE, gun | 1 |
| 20* | 15F216 | HOLDER, gun | 1 | 70* | 119648 | SCREW, mach, trussd, cross recess | 1 |
| 20a* | 15F750 | HOLDER, gun, knob | 1 | 73* | 113428 | SCREW, cap, socket, flthd | 2 |
| 20b* | 15F214 | LEVER, actuator | 1 | 77 | 188135 | GUIDE, cable | 1 |
| 20c* | 15F209 | STUD, pull trigger | 1 | 156 | 69319ST | TIP, spray, striping | 1 |
| 20d* | 24Y991 | KIT, pivot | 1 | | 69317ST | TIP, spray, striping | 1 |
| 20e* | 15F211 | STUD, cable | 1 | | *17H720 | STRAP, tie | 3 |
| 20f* | 102040 | NUT, lock | 3 | 157 † | 195558 | SEAT, cylinder | 1 |
| 20g* | 24Y991 | KIT, pivot | 1 | | 115524 | GASKET | 1 |
| 21 | 248200 | GUARD, Uni-Tip | 1 | | | | |
| 23 | 287566 | KIT, clamp | 1 | | | | |
| 24* | 17J145 | ARM, holder, gun | 1 | | | | |
| 25* | 15F213 | BRACKET, cable | 1 | | | | |

* Included in Gun Holder Repair Kit 25A528
 † Included with 156

Pressure Control/Filter Assembly

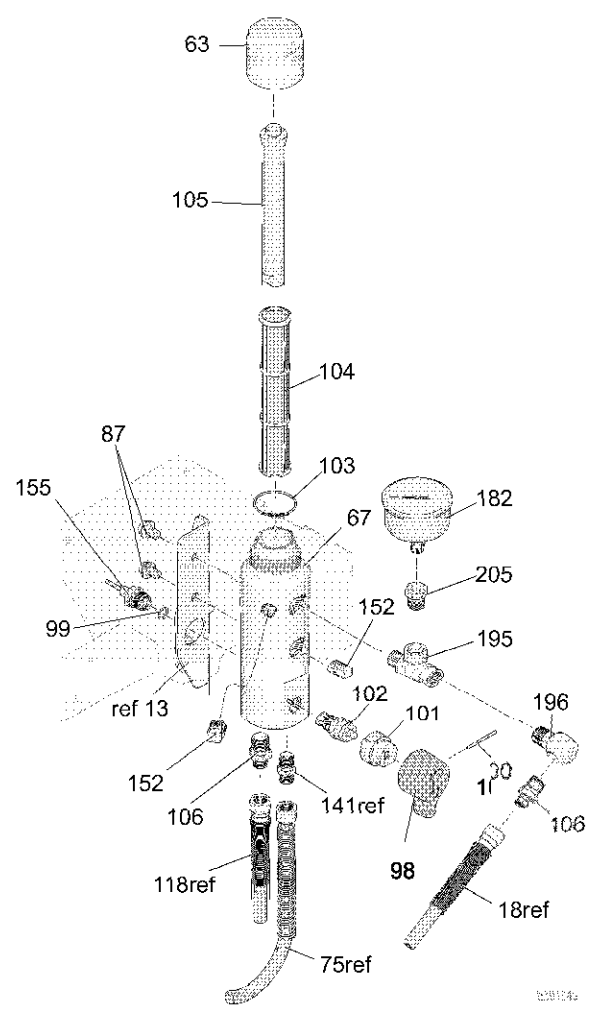
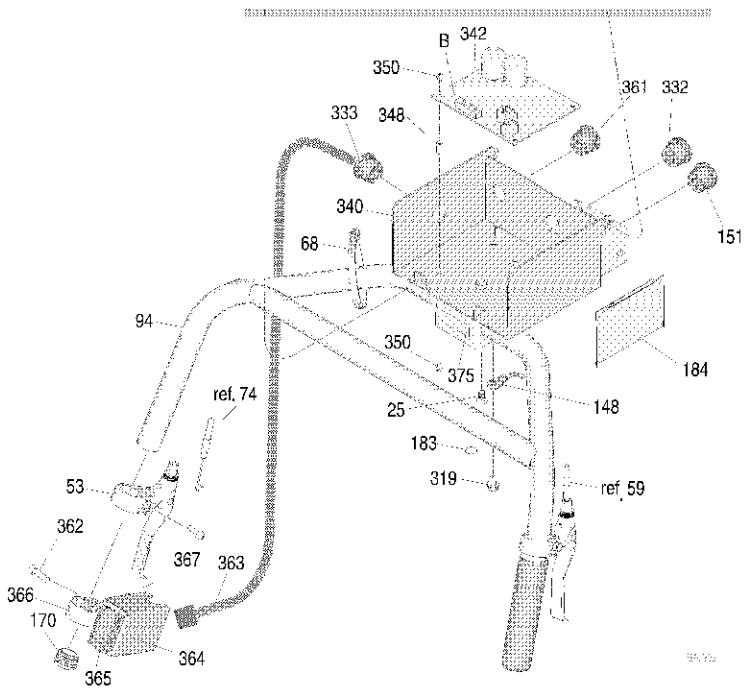
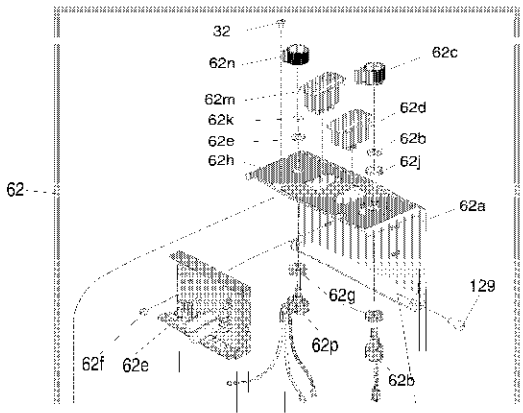

Parts List - Pressure Control/Filter Assembly

| Ref | Part | Description | Qty | Ref | Part | Description | Qty |
|------|--------|----------------------------------|-----|------|--------|--------------------------------------|-----|
| 25 | 108538 | SCREW, cap, flat hd | 1 | 148 | 237686 | WIRE, ground, assembly w/ clamp | 1 |
| 53 | 194310 | LEVER, actuator | 2 | 151 | 15F928 | BUSHING, strain relief | 1 |
| 62 | 24Z793 | COVER, control box, assy | 1 | 152* | 15G331 | PIPE, plug, sst | 2 |
| 62a | 17N544 | COVER, control box | 1 | 155* | 15F782 | HARNESS, transducer, line striper | 1 |
| 62b | 129631 | POTENTIOMETER | 1 | 170 | 120151 | PLUG, tube | 2 |
| 62c | 116167 | KNOB, potentiometer | 1 | 182* | 804582 | GAUGE, pressure fluid | 1 |
| 62d | 116752 | SWITCH, rocker | 1 | 183 | 16W503 | LABEL, ground symbol | 1 |
| 62e | 17R784 | BOARD, control, motor | 1 | 184 | 17P264 | LABEL, safety | 1 |
| 62f | C19862 | NUT, lock hex | 4 | 195* | 124490 | FITTING, tee | 1 |
| 62g | 198650 | SPACER, shaft | 2 | 196* | 196179 | FITTING, elbow | 1 |
| 62h | 17N702 | LABEL, controls | 1 | 205* | 129535 | BUSHING, pipe | 1 |
| 62j | 15C973 | GASKET | 1 | 330 | 24Z794 | HOUSING, switch, assy | 1 |
| 62k | 129509 | O-RING, 70 durometer | 1 | 332 | 129433 | BUSHING, strain relief | 1 |
| 62m | 17N906 | SWITCH, rocker, LED | 1 | 333 | 129434 | BUSHING, strain relief | 1 |
| 62n | 17N957 | KNOB, potentiometer | 1 | 340 | 17N545 | BASE, box, control | 1 |
| 62p | 17R749 | POTENTIOMETER, speed | 1 | 342 | 24Z718 | BOARD, control, pump | 1 |
| 63* | 15C765 | CAP, manifold, includes 103, 105 | 1 | 348 | 129510 | STANDOFF, thd, hex | 4 |
| 67* | 17K166 | MANIFOLD, filter | 1 | 350 | 103854 | SCREW, mach, BDGH | 8 |
| 87 | 111801 | SCREW, cap, hex hd | 4 | 361 | 111348 | BUSHING, strain relief | 1 |
| 94 | 24Z284 | BAR, handle, weldment | 1 | 362 | 513035 | SCREW, cap, M6 x 20mm | 1 |
| 98* | 15C780 | HANDLE | 1 | 363 | 17N299 | HARNESS, wiring | 1 |
| 99* | 111457 | O-RING | 1 | 364 | 17P942 | COVER, switch, housing | 1 |
| 100* | 15C972 | PIN, grooved | 1 | 365 | 17N907 | SWITCH, D-N-Cruise | 1 |
| 101* | 224807 | BASE, valve | 1 | 366 | 17N514 | BASE, mount, switch | 1 |
| 102* | 239914 | VALVE, drain | 1 | 367 | 103854 | SCREW, #6 x .25 | 4 |
| 103* | 117285 | O-RING | 1 | 375 | 17R193 | LABEL, prime, charge | 1 |
| 104* | 243984 | FILTER, fluid | 1 | | | | |
| 105* | 15C766 | TUBE, diffusion | 1 | | | | |
| 106* | 196177 | ADAPTER, nipple | 2 | | | | |
| 129 | 101550 | SCREW, cap, sch | 2 | | | | |

* Included in Filter Repair Kit 17P809

Pressure Control Wiring Diagram

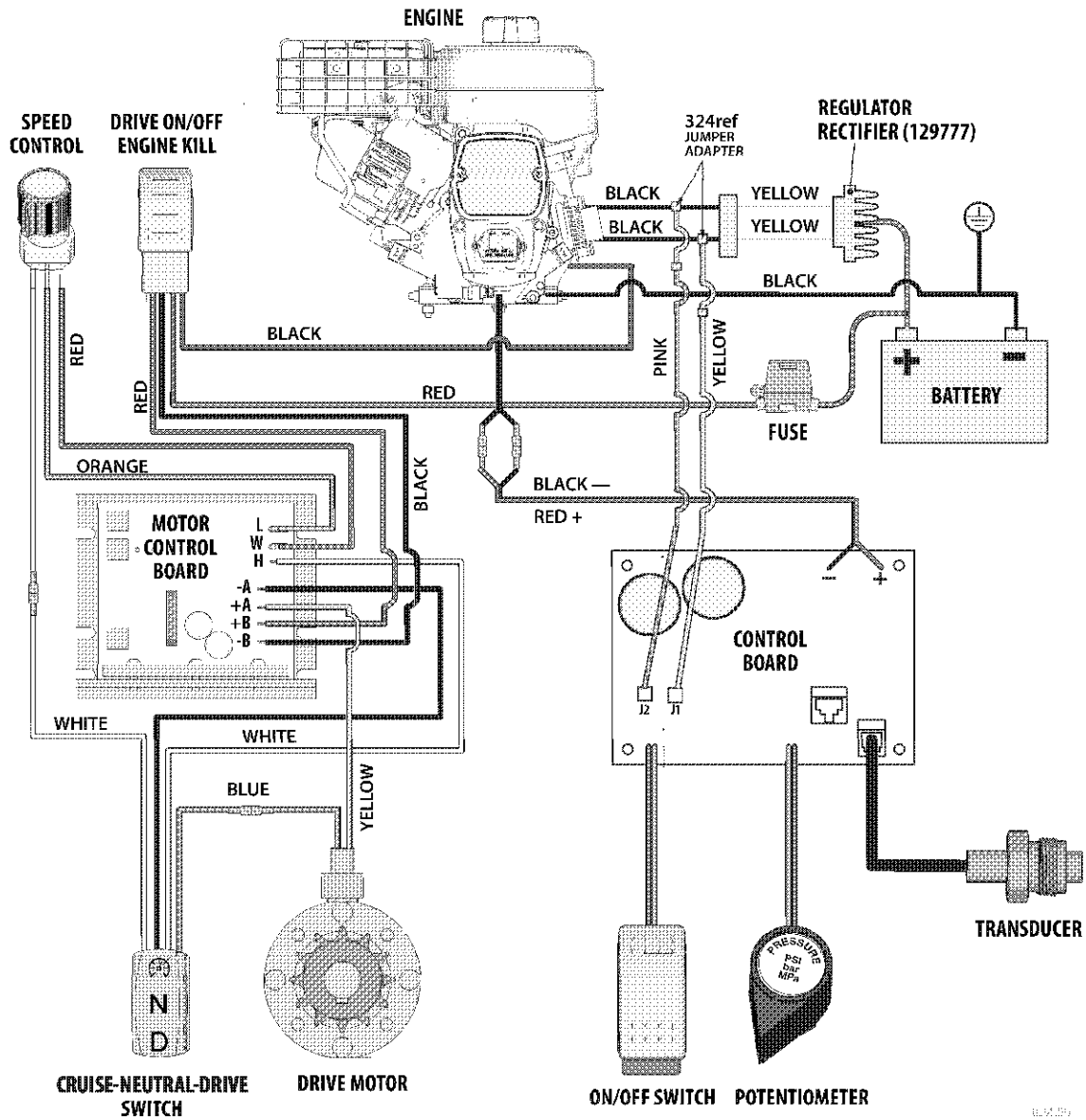

Drive Control Wiring Diagram

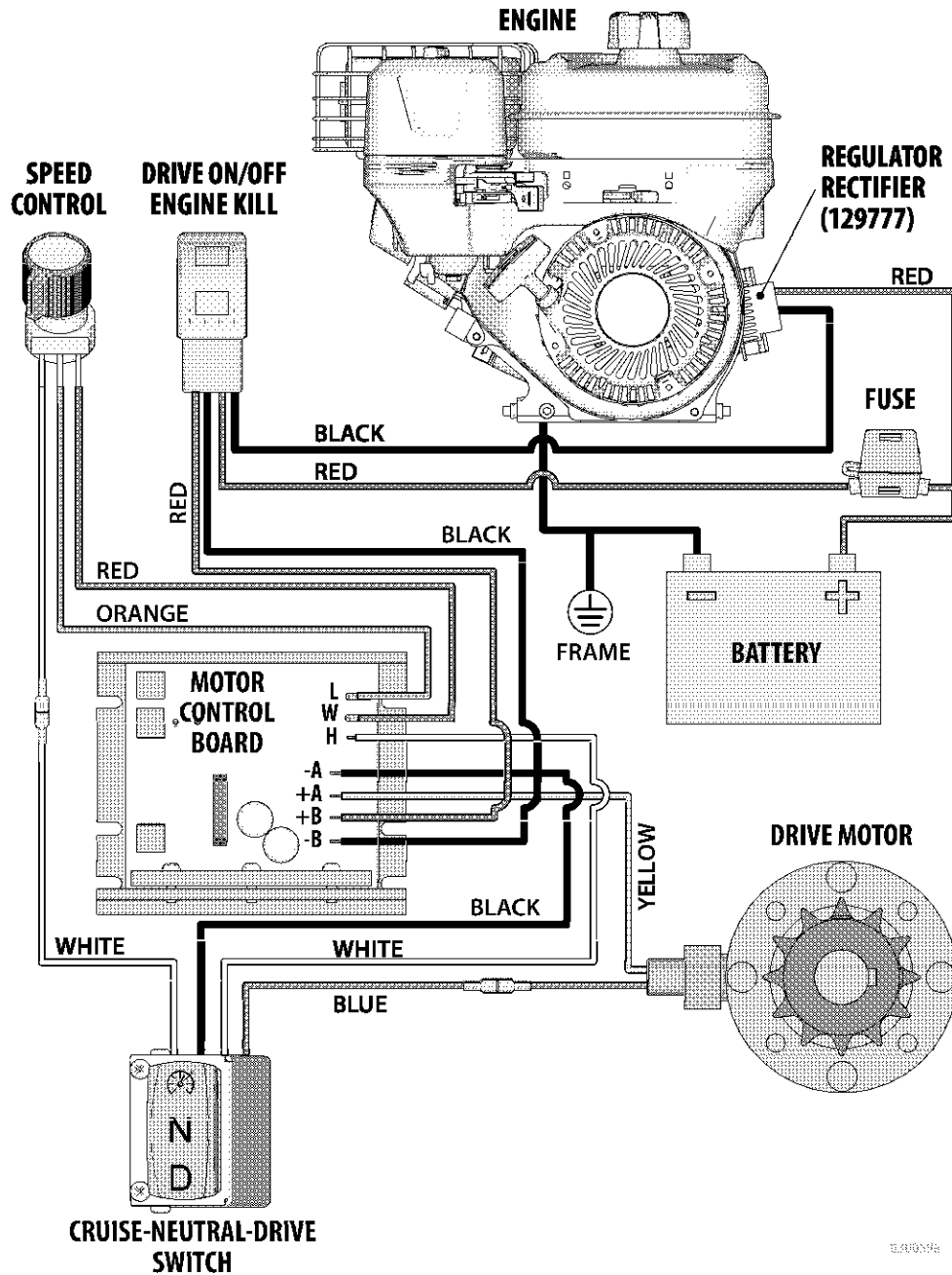

PIONEER LIMITED WARRANTY

PIONEER warrants the Brite Striper 3500SP manufactured by it to be free from defects in material and workmanship on the date of sale by an authorized PIONEER Distributor to the original purchaser. Pioneer will, for the period of two (2) years from the date of sale, repair or replace any part of the equipment proven defective. This warranty applies only when the equipment is installed, operated and maintained in accordance with Pioneer's written recommendations.

This Warranty does not apply to equipment which has been resold or rented, or has damage from wear caused by abrasion, corrosion or misuse, negligence, accident, faulty installation or tempering in a manner to impair normal operation, inadequate or improper maintenance or substitution of non-Pioneer component parts.

This warranty is conditioned upon the prepaid return of the equipment claimed to be defective to a Pioneer authorized service center for verification of the claim. If the claim is verified, Pioneer will repair or replace free of charge any defective parts. The equipment will be returned to the original purchaser transportation prepaid. If inspection of the equipment does not disclose any defect in material or workmanship, repairs will be made at a reasonable charge, which charges may include the costs of parts, labor, and transportation.

Pioneer makes no warranty, and disclaims all implied warranties of merchantability and fitness for a particular purpose, with respect to accessories, equipment, materials or components sold but not manufactured by Pioneer. These items sold, but not manufactured by Pioneer, such as engines, hoses, etc, are subject to warranty, if any, of their manufacturer. Pioneer will provide purchaser with reasonable assistance in making any claim for these warranties.

TO PLACE AN ORDER OR FOR SERVICE, contact Pioneer at
1-800-877-1500 (fax 1-800-877-1511) to identify the nearest service center.

*All written and visual data contained in this document reflects the latest product information available at the time of publication.
Pioneer reserves the right to make changes at any time without notice.*

For patent information, see www.graco.com/patents.

Original instructions. This manual contains English. MM 3A4558

Pioneer Athletics
4529 Industrial Parkway
Cleveland, OH 44135
www.pioneerathletics.com
Revised B, June 2017