



BRITE STRIPER[®]

PROFESSIONAL SERIES

1600 PS

INSTRUCTION MANUAL & PARTS LISTING

BRITE STRIPER® 1600 PROFESSIONAL SERIES

• **3-YEAR LIMITED WARRANTY** •

Versatility

The MODEL 1600 PS handles all athletic field needs with ease. So simple to operate that anyone can do a professional job.

5-YEAR WARRANTY AGAINST "RUST OUT"

Ample 12 gallon paint tank tackles large striping needs in a snap. Pioneer's 5-year warranty (against rust) is on the stainless steel paint tank

STURDILY BUILT FOR YEARS OF SERVICE

Honda 3 H.P. engine powers a Piston-Type Compressor. Heavy-gauge welded steel frame rolls smoothly on three large, fully pneumatic wheels. The MODEL 1600 PS has a cable-operated control valve to paint crisp lines.

SIMPLE DESIGN

- LOW MAINTENANCE

The MODEL 1600 PS's simple design means low maintenance. The air-release valve and dual safety relief system assures trouble-free operation. Rear outlet valve makes cleanup a snap.

FULLY ADJUSTABLE SPRAY BOX

Change line width easily from 2" to 8". Two-head sprayer standard.

12' HAND HOSE WITH WAND

A twelve-foot hand hose (and spray gun) with wand and quick disconnect fitting is standard on our BRITE STRIPER® 1600 PS. Get professional results on yard-line stencils, endzones and out-of-bounds.

SPECIAL TUNE-UP KIT FOR BRITE STRIPER® 1600 PS

Our exclusive tune-up kit, as an accessory, for this model includes:

- 2 Nozzle Tips
- 2 Nozzle Screens
- 2 Nozzle Caps
- 1 Tank Gasket
- 1 Shut-Off Repair Kit
- 1 Safety Relief Valve
- 1 Drive Belt
- 1 spark Plug
- 1 Air Filter

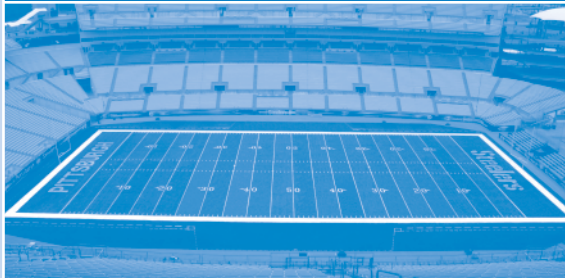

Replacement parts for all of Pioneer's machines are fully stocked and available for immediate delivery. We also carry replacement parts for many other airless line strippers. Call your local representative or Pioneer for more information.

Call 800.877.1500

PN07014

to order BRITE STRIPER® Accessories

TABLE OF CONTENTS

THE BRITE STRIPER® 1600 PS

ASSEMBLY INSTRUCTIONS

Tools Necessary for Assembly	1
Removing from Shipping Carton	1
Handle Assembly	1
Adjustable Spray Box	2

OPERATION & CARE

Before Starting.	3
Care and Operation of Compressor.	4
Care and Operation of Paint Tank Unit	5
Paint Tank Label	5
Operation of Machine	6
Striping Tips.	9
Clean-Up of the Paint Tank Unit	10
Clean-Up Tips.	11
How to Store	11
Normal Wear	11
Customer Service.	14
Shipping the Product.	14

IDENTIFYING PROBLEMS & PARTS

Parts List & Parts Explosion Drawings	7-8
Trouble Shooting the #1600	12-13
Limited Warranty	15

WARNING: ENGINE IS NOT SHIPPED WITH MOTOR OIL.

If you have any questions concerning the assembly or operation, please call our CUSTOMER SERVICE DEPARTMENT at 800.877.1500.

TOOLS NEEDED FOR ASSEMBLY

- 1 - 5/8" Open End Wrench
- 1 - 7/16" Socket
- 1 - 7/16" Open End Wrench
- 1 - Crescent Wrench (Vise Grips may be substituted)
Allen Wrenches (supplied in hardware kit)

ASSEMBLY INSTRUCTIONS FOR BRITE STRIPER® MODEL #1600 After Removing Box from Shipping Carton:

STEP 1.

Remove Brite Striper 1600 – two people necessary to lift

STEP 2.

Remove handle bar.
Remove box containing:
12 Ft. Hand Hose Assembly
Hand Hose Wand
Drain Line
Shut-Off Valve Assembly

STEP 3.

Handle Assembly
Parts required:
a. Handle
b. Handle adjustment bolts
Step 1: Slide handle into frame
Step 2: Insert handle adjustment bolts
Step 3: Attach paint control lever to handle

NOTE: TEST CONTROL TRIGGER TO MAKE SURE CABLE IS ADJUSTED PROPERLY. CABLE SHOULD HAVE SMALL AMOUNT OF SLACK.

ADJUSTABLE SPRAY BOX

PARTS REQUIRED:

2 ea	3/4" x 1/4" - 7/16" Hex Head Bolts
2 ea	7/16" Hex Head Self-Locking Nuts
1 ea	Snap Ring
1 ea	Adjustable Spray Box

TOOLS REQUIRED:

7/16" Socket & Ratchet
7/16" Open End Wrench
5/8" Open End Wrench
Snap Ring Pliers or Screwdriver
Allen Wrenches

STEP 1.

Slide Adjustable Spray Box Bar on front axle. Align holes on Spray Box Support Bracket with holes on the front of the frame. Insert 2 hex head bolts from top of Spray Box Support Bracket and attach self-locking nuts from bottom of frame and tighten completely. Attach Snap Ring on end of axle to prevent Spray Box Bar from sliding off.

STEP 2.

Attach free end of paintline hose to two-headed sprayer assembly on Adjustable Spray Box and tighten with 5/8" open end wrench.

(DO NOT OVER TIGHTEN). MAKE SURE NOZZLE TIP IS ALIGNED HORIZONTALLY WITH GROUND.

Use supplied Allen Wrenches to adjust side plates for proper width. Adjust bar height by loosening wing nut and setting desired height, retighten wing nut. Side plates may need to be adjusted up or down depending on height of Spray Box Bar. Use supplied Allen Wrenches. Do not over tighten side plates. **SIDE PLATES SHOULD BE ABLE TO MOVE UP AND DOWN BY HAND.**

BEFORE STARTING

The 1600 PS STRIPER is shipped **WITHOUT ENGINE OIL**. Be sure to check the enclosed Operating and Maintenance instructions for proper oil. Follow filling directions.

1. Carefully read and follow instructions for starting and maintaining the engine (in a separate booklet furnished with your machine).
2. Check all hose connections and fittings making sure they are tight.
3. Be sure paint tank pump assembly is sealed tightly. Refer to care and operation of tank unit section.
4. Check to make certain that paint tank is secured tightly.
5. Any fittings, if replaced, should have teflon tape applied before tightening. Do not force fittings on paint tank bushings. Always hold nut on paint tank bushing when tightening fittings.

DO NOT TIGHTEN FITTINGS WITH PRESSURE IN TANK.

CARE AND OPERATION OF COMPRESSOR

The piston-type compressor requires minimal maintenance.
Pre-lubricated ball bearings for delivery of oil free air.

**APPLYING OIL TO ANY PART CAN RESULT IN REDUCED PERFORMANCE
AND MAY VOID WARRANTY.**

The compressor is designed to release pressure at approximately 40 to 45 PSI. If it is not releasing, contact us immediately. You may have a defective or damaged relief valve.

The air filter should be replaced whenever it becomes dirty and/or clogged.

Operate compressor at lowest engine speed practical.

CARE AND OPERATION OF PAINT TANK UNIT

DIRECTIONS FOR OPERATING:

1. Remove pump assembly by raising locking lever to vertical position, and turning counterclockwise until ends of locking lever reach slots in locking ring; lift out.
2. Mix paint (in pail - not in tank) and strain through cloth or fine sieve. Paint Strainer Filters packaged 25 per case are available. Use item #PS 25 when ordering.
3. Fill tank 3/4 full, leaving remaining space for compressed air.
4. Replace pump assembly in tank, holding locking lever up in vertical position, turn clockwise about halfway, and push locking lever down to seal. Do not force. **NEVER USE TOOL TO TIGHTEN PUMP ASSEMBLY.**
5. Optional method of pressurizing paint tank: You can build pressure by using the handle of the pump assembly. Pump plunger up and down until sufficient pressure builds up and spray becomes fine; re-engage pump handle by pushing down against spring and turning back into retaining slots.

WARNING

1. Release pressure with pressure release valve when not in use. NEVER use any tool to remove pump if there is pressure in the tank. Failure to follow this instruction may result in personal injury or damage.
2. Never stand with head or body over top of tank when operating or removing pump. Failure to follow this instruction may result in personal injury.
3. Periodically test hose for strength and make sure all fittings are secure. Replace worn hose with recommended replacement parts (refer to parts list).
4. We recommend the use of goggles when spraying. Failure to follow this instruction may result in personal injury.

PAINT TANK LABEL

WARNING: IMPROPER USE OR FAILURE TO FOLLOW INSTRUCTIONS CAN RESULT IN EXPLOSIVE FAILURE WITH MAJOR INJURIES. FOR SAFE USE OF THIS PRODUCT—YOU MUST READ AND FOLLOW ALL INSTRUCTIONS BEFORE USE.

CAUTION: Do not leave a pressurized sprayer in the hot sun. Heat can cause pressure build-up. Do not store or leave solution in tank after use. Always wear goggles, gloves, long sleeve shirt, long pants and full foot protection when spraying. Never use any tool to remove pump if there is pressure in sprayer. Never stand with face or body over top of tank when pumping or loosening pump to prevent ejected pump assembly and/or solution from striking and injuring you. Never pressurize sprayer by any means other than the original pump. Do not attempt to modify or repair this product except with original manufacturer's parts. NEVER SPRAY FLAMMABLE MATERIALS OR PRESSURE AND GAS PRODUCING CHEMICALS SUCH AS SODIUM HYDROXIDE. ALWAYS READ CHEMICAL LABEL BEFORE FILLING SPRAYER AS SOME CHEMICALS MAY BE HAZARDOUS WHEN USED WITH THIS SPRAYER. PRE-USE CHECK: Remove pump (see filling, pressurizing and spraying instructions), inspect interior and exterior of tank for signs of deterioration (i.e. rust, bubbling and/or pitting) of body and bottom. Any sign of deterioration indicates possible tank weakening and could result in explosive bursting under pressure. If any of these signs are found, discard tank immediately and replace. Do not attempt to patch leaks, etc., as this could result in serious injury. Follow filling, pressurizing and spraying instructions EXCEPT: Use water only. Pump plunger only 8-10 strokes and inspect for leaks. Open discharge to make sure it is not clogged. If unit passes this test, release pressure (see pressure releasing instructions), empty tank, and proceed with filling, pressurizing and spraying instructions. FILLING, PRESSURIZING AND SPRAYING INSTRUCTIONS: To engage handle in lock position: Push handle down to completely compress spring and rotate handle 1/4 turn, then allow handle to raise into the lock position. To remove pump from: FUNNEL TOP STYLE: Engage handle in locked position and turn pump counterclockwise until pump can be removed from tank. 3-PRONG CLAMP OPEN HEAD STYLE: Turn handle counterclockwise until 3-prong clamp is loose. Then rotate clamp counterclockwise to stop and lift pump out. LOCKING LEVER OPEN HEAD STYLE: Engage handle in locking hooks then lift locking lever to its most upright position. Turn pump counterclockwise until prongs are located under slots in funnel and lift pump out. THREAD CAP STYLE: Engage handle in lock position and turn pump counterclockwise until pump can be removed from tank. Prepare spray solution following directions on chemical container label. Strain

solution and fill tank to indicated usable capacity, leaving remaining space for compressed air. To close after filling: NOTE: Check pump barrel to be sure no dirt or grass is stuck to barrel. FUNNEL TOP STYLE: By placing pump into tank opening and rotating clockwise until tightly locked and sealed in tank opening. 3-PRONG CLAMP STYLE OPEN HEAD: Place pump prongs down into slots in funnel. Turn clamp clockwise to furthest position under bottom slot, then turn handle clockwise until tightly locked and sealed in place. LOCKING LEVER OPEN HEAD STYLE: Lift locking lever into upright position. Place pump prongs into slots in funnel. Turn pump clockwise until it stops, then push locking lever down to funnel to lock and seal in place. THREAD CAP STYLE: Place pump into tank opening then rotate clockwise until tightly locked and sealed in tank opening. To pressurize sprayer disengage handle from locked position, push down, turning 1/4 turn to release handle and then pump plunger up and down until it works hard. Refer to filling, pressurizing and spraying instructions: To engage handle in lock position.

WARNING: THIS SPRAYER IS NOW UNDER PRESSURE AND DANGEROUS.

Always wear goggles, gloves, long sleeve shirt, long pants and sturdy foot protection when spraying. Re-pump unit as required to maintain spray force.

PRESSURE RELEASE INSTRUCTIONS: WARNING: To avoid possibility of ejected pump assembly and/or spray material from striking and injuring you: Place unit on its side with top directed away from you with outlet on top, open discharge and allow remaining spray solution and pressure to be completely exhausted. Turn sprayer upright, then remove pump (follow filling, pressurizing and spraying instructions), while maintaining position of top of sprayer away from you.

SPRAYER CARE, STORAGE AND MAINTENANCE: Clean tank and discharge thoroughly. Remove pump and empty sprayer. Sprayer tank should be hung upside down, with pump removed, in a warm dry location. Pump should be periodically oiled by dropping 10-12 drops of light oil down pump rod through opening in cover. At least twice a year and always before storage, remove pump barrel from cover assembly, apply a small amount of vaseline or other similar lubricant to barrel threads and assemble (if applicable).

SK-637-S R5050

OPERATION OF MACHINE

1. Check to make certain that brass bleed-off valve (located on cross fitting) is in closed position so air will not escape.
2. Make certain that your V-belt is tight.

WARNING: NEVER OPERATE UNIT WITHOUT BELT GUARD IN PLACE. FAILURE TO FOLLOW THESE INSTRUCTIONS MAY RESULT IN PERSONAL INJURY OR DAMAGE.

3. Test run the machine with water to see how it operates. You may wish to practice using paint in an off-area before starting your job.
4. Start your engine. Allow compressor to build up pressure in your paint tank from 40 to 45 PSI at which point air will automatically release through the safety relief valve on the compressor unit. This should only take a few minutes. Check again for loose fittings or air leaks.

Note: The compressor unit is designed to deliver pressure between 40 to 45 PSI. A low pressure gauge is installed so that you may be sure machine is at proper operating pressure. A safety relief valve on the paint tank is pre-set to relieve pressure at 50 PSI \pm 2 lbs.

5. It is best to operate at the lowest pressure and slowest engine speed that is practical. This will greatly reduce wear and prevent overspraying.
6. When done or when changing paint, always turn off machine.
7. Bleed off pressure by opening the brass bleed-off valve located at the top of paint tank.

WARNING: ALWAYS BLEED OFF PRESSURE IN PAINT TANK BEFORE OPENING PUMP ASSEMBLY! ! ! FAILURE TO FOLLOW THESE INSTRUCTIONS MAY RESULT IN PERSONAL INJURY OR DAMAGE.

8. When transporting machine, do not tip on side when filled with paint.

PARTS LIST

BRITE STRIPER® MODEL 1600 PS

KEY#	PART #	DESCRIPTION	KEY#	PART #	DESCRIPTION
1	1503	Hand Grip	20	1627	Engine
2	1505	Paint Control Lever	--	1619	Engine Pulley
3	1636	Paint Control Cable	--	1611	*Air Cleaner
4	1609	20" Airline Hose	--	1616	*Spark Plug
5	0311	Low Pressure Gauge	--	1606	*Drive Belt
6	0104	Tee with Nipple	21	1500	12 Gal. Paint Tank
7	1532	Check Valve	22	0080	Bushing Fitting
8	1215	Rear Wheel	23	0103	*Safety Relief Valve
--	1528	Rear Axle	24	0090	Cross Fitting
9	0096	Brass Nipple	25	0125	Bleed-off Valve
10	1629	Safety Relief Valve	26	1102	Pump Assembly
11	1635	Shut-Off Valve	--	0119	*Tank Gasket
13	1638	50" Paint Line Hose	--	0076	Rubber End for Pump Assy.
14	1523	2-Head Sprayer Assy.	27	5088	Female Quick Disconnect
15	1524	Side plate	28	0116	Nozzle Body
--	1544	Side Plate or Nozzle Assy. Clamps	29	0115	*Nozzle Screen
16	1546	Spray Box Support Arm	30	0112	*Nozzle Tip
17	1542	Height Adjustment Bracket	31	0114	*Nozzle Cap
18	1216	Front Wheel	--	0135	Nozzle Assembly Kit (4 ea. #0112, #0115, 2 ea. #0114)
--	1531	Front Axle	--	1621	Handle
--	1218	Wheel Bearings	--	1625	Frame
19	1630	Compressor	--	1626	Belt Guard
--	1618	Compressor Pulley	--	1212	12' Hand Hose with Wand
*Indicate parts included for Tuneup Kit part # 1601			--	1213	12' Hand Hose only
			--	0094	Wand only
			--	1515	20' Hand Hose with Wand
			--	1533	Drain Hose 4'
			--	1550	Track Boom Assy.

PARTS LIST

BRITE STRIPER® MODEL 1600 PS

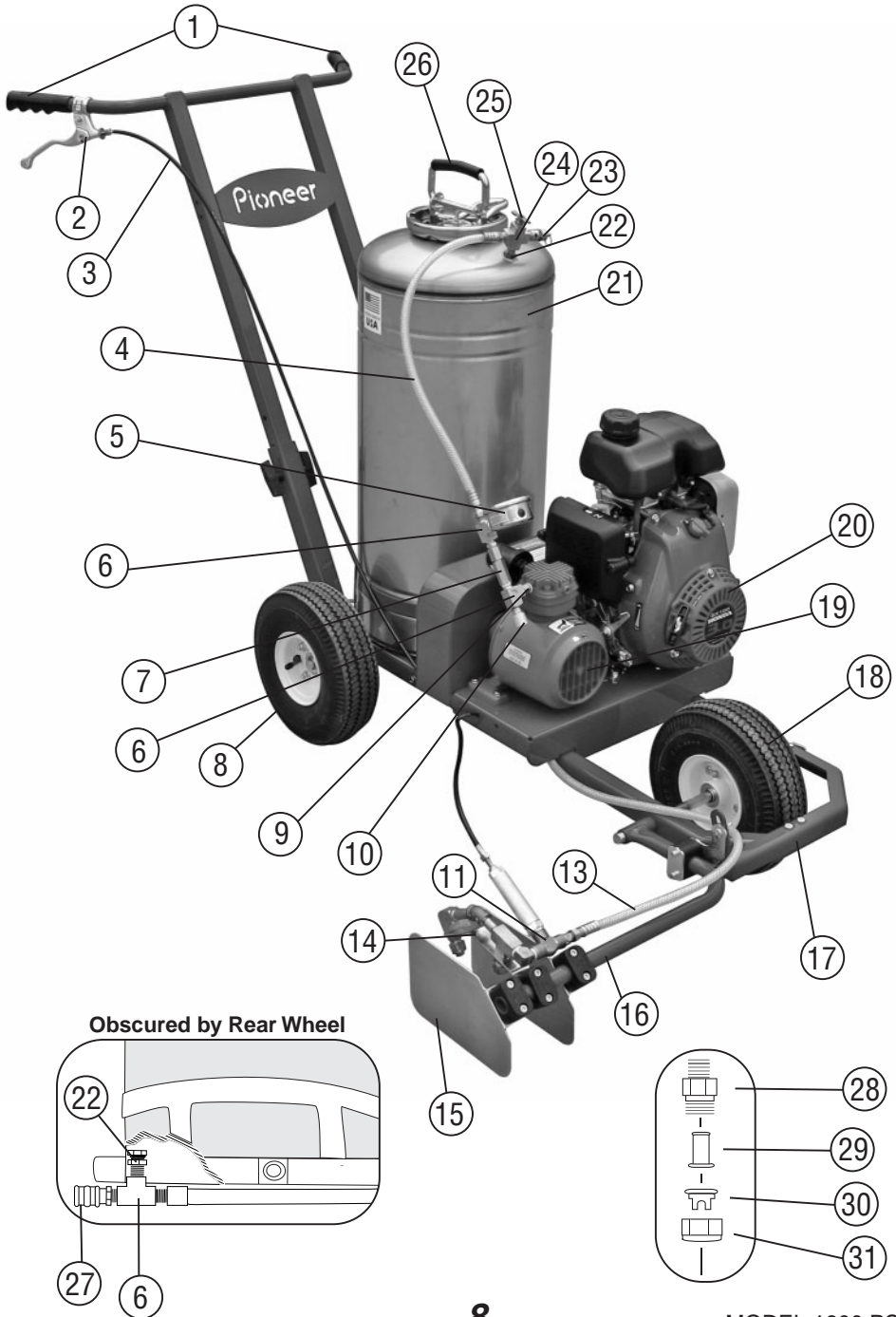

STRIPING TIPS

When striping always have the machine in motion before opening the spray valve, thus eliminating a heavy “blob” of paint at the beginning.

If striping on an asphalt or concrete surface you may have a build-up of paint on the edges of your line. This can be corrected by adjusting the tip so the fan spray is angled at 45 degrees to each side plate. Adjust so spray barely touches plates and your build-up will be eliminated or reduced. Call for other spray tips.

When releasing pressure on the paint tank, hold a rag over the brass bleed-off valve, as paint may have splashed up to the bleed-off valve and will be blown out.

Simplest method for running test lines is to apply lines on paper or an off-area. For a sharp cut-off at end of a line, place paper or cardboard at end, so the line is square.

Periodically clean or replace the screen and tip located inside the spray box assembly.

Run your engine at the slowest speed possible. This will greatly decrease wear and tear on your entire machine.

CLEAN-UP OF THE TANK UNIT

1. Discharge remaining paint through drain hose (supplied with unit) into clean container. Cap container tightly for next use.
2. Shut off gas engine.
3. Release pressure in the paint tank with brass bleed-off valve.
WARNING: NEVER USE ANY TOOL TO REMOVE PUMP IF THERE IS PRESSURE IN THE TANK. FAILURE TO FOLLOW THESE INSTRUCTIONS MAY RESULT IN PERSONAL INJURY OR DAMAGE.
4. Remove Pump Assembly. Hose the inside of the tank to remove any excess paint. Fill tank 3/4 full with water and Pioneer P.H.D. Solution. Scrub inside of paint tank with soft nylon bristle brush, available through Pioneer, Item # TBrush.
5. Replace pump assembly and lock in place.
6. Start gas engine and pressurize tank to proper operating pressure, or use hand pump.
7. Discharge water and P.H.D. Solution through adjustable spray box alternating to hand hose (if hand hose was used) until tank is empty.
8. Shut off engine — release pressure in paint tank.
SEE STEP 3 ABOVE.
9. Remove pump assembly and fill paint tank 1/4 full of clean water. Replace pump assembly and lock in place.
10. Start gas engine and pressurize tank to proper pressure.
11. Discharge water through adjustable spray box and hand hose (if used) until tank is empty. **REPEAT ABOVE STEP UNTIL WATER COMES OUT CLEAR.**

CLEAN UP TIPS

All parts of your PIONEER Brite Striper® should be cleaned **immediately after each use**. We recommend Pioneer P.H.D. Cleaner. A clean, lint-free rag should be used to wipe dry the inside of the tank.

A final step should then be to remove the nozzle caps and clean the nozzle tips and screens. This can easily be done by placing all three parts into a small can of soapy water and allowing them to soak for a few minutes. An old toothbrush can be used for stubborn spots. Rinse Nozzle Assembly parts with clean water and allow to air dry. Do not store with pump locked in tank, leave loose.

CAUTION: DO NOT USE WIRE OR ANY OTHER OBJECT TO CLEAN NOZZLE TIP AS THIS MAY CAUSE TIP ORIFICE TO BECOME ENLARGED WHICH WILL RESULT IN POOR PERFORMANCE WHEN STRIPING.

HOW TO STORE

Cleaning your machine thoroughly cannot be overemphasized. A little extra effort at the end of each job will save you time and money when it is time to stripe again. As stated previously, run a tankful of water through the machine. Be sure to clean out screen inside the Nozzle Assembly.

IMPORTANT: BE SURE TO CLEAN PUMP UNIT IN TANK. IMMERSE IN CLEANING SOLUTION AND PUMP SEVERAL TIMES. FAILURE TO DO THIS MAY RESULT IN LEAKS OR MALFUNCTION IN THE UNIT.

When storing your striper for an extended period, do the following:

1. Flush machine out thoroughly.
2. Remove hoses and drain.
3. Run engine until gas tank is empty.
4. Wipe the sides and bottom of the inside of the tank with a clean dry rag.
5. Lubricate spray valve (shut-off valve).
6. Apply vaseline or similar substance to pump gasket.
7. Do not store with pump assembly tight.

NORMAL WEAR

Warranty will not cover repair where normal use has exhausted the life of the part. Line stripers, like all mechanical devices, need periodic parts replacement and service to perform well. It should be remembered that the service life of any equipment is dependent on the care it receives and the conditions under which it has to operate.

TROUBLE SHOOTING

Brite Striper® Model #1600

STRIPER DOES NOT STRIPE FULL LINE

1. Was paint strained?
2. Check paint level.
3. Check nozzle screen for clogs. Clean as needed.
4. Check nozzle tip for proper alignment — horizontal.
5. Check operating pressure — is air releasing through safety release valve on compressor?
6. Check airline hose fittings — tighten as needed.
7. Check pulleys and belt. Adjust as necessary.
8. Check shut-off valve for clogs — clean. Adjust control cable.
9. Check paint line hose for clogs — clean.

HAND HOSE ASSEMBLY DOES NOT SPRAY PROPERLY

1. Check nozzle, screen and tip for clogs — clean as needed.
2. Check operating pressure.

PAINT LEAKS

PAINT TANK LEAKS PAINT

Check that fittings are tight.

PUMP ASSEMBLY LEAKS PAINT THROUGH CENTER

Check to be sure rubber end on bottom of pump assembly is not being held open by dry paint.

PAINT LINE HOSE LEAKS PAINT

Check paint line hose fitting — tighten.

NOZZLE ASSEMBLY LEAKS

Tighten nozzle assembly.

SHUT-OFF VALVE LEAKS PAINT

Check that shut-off valve is tightened. Check control cable adjustment.

AIR LEAKS

PUMP ASSEMBLY LEAKS AIR

1. Shut off machine.
2. Bleed pressure from paint tank.
3. Remove pump assembly and check tank gasket for damage – replace if needed. Re-seat in pump assembly. Do not overtighten.
4. Check that brass tube is threaded tightly against top of pump assembly. Also, check plastic cup at bottom of shaft for excessive wear. Repair with pump assembly and shut-off repair kit.

AIR LINE HOSE LEAKS AIR

1. Check air line hose for breaks/cuts. Replace as needed.
2. Tighten air line hose fittings.

STRIPER WILL NOT ROLL EASILY

1. Wheels should spin freely – lubricate bearings.
2. Paint line hose and 12' hand hose should clear wheels.

STRIPER USES TOO MUCH PAINT

1. Opening in nozzle tip enlarged.
Replace with new nozzle tip.
2. Tank building too much pressure.

**CALL OUR CUSTOMER SERVICE REPS
FROM 8:00a.m. - 5:00p.m. (EST) 1-800-877-1500**

with any questions you may have concerning the care, assembly, operation, or maintenance of this product. Before you call be sure that unsatisfactory operation is not due to inadequate care or cleaning, abuse, or neglect. This may save you time and money. See our warranty for specific coverage.

IF YOU SHIP THE PRODUCT

PRIOR AUTHORIZATION MUST BE RECEIVED BEFORE RETURN

Carefully pack unit and send it prepaid and adequately insured.

Attach a postage-affixed letter, detailing the complaint, to the outside of the carton. **BE SURE TO SHOW RETURN AUTHORIZATION CODE NUMBER ON OUTSIDE OF ENVELOPE.**

**FOR ANY REPAIRS INCLUDING
WARRANTY REPAIRS:**

Call 800.877.1500 for repair cost estimates, and full service information, **INCLUDING RETURN AUTHORIZATION CODE NUMBER, BEFORE SENDING YOUR UNIT.**

SEND YOUR UNIT, FREIGHT PREPAID TO:

**PIONEER MANUFACTURING COMPANY
4529 Industrial Parkway
Cleveland, Ohio 44135**

LIMITED WARRANTY

For a period of three years from date of purchase, PIONEER MANUFACTURING COMPANY will replace for the original PURCHASERS, any part or parts* of the line Striper (a five (5) year limited warranty against rust-out on stainless steel tanks), found upon examination by a PIONEER FACTORY-trained representative, to be defective in material or workmanship or both; this is the exclusive remedy. This warranty is pro-rated as to cover 100% of the cost of materials, parts and labor for the first twelve months of ownership, 60% the second twelve months, and 40% for the third twelve month period. The customer is responsible for all remaining costs. The customer may elect to return the entire unit to the factory at his expense for repair. Or he may, at his expense, return the defective part for factory inspection AND replacement. In no case will PIONEER MANUFACTURING authorize outside repair on any unit nor will PIONEER MANUFACTURING reimburse any customer for unauthorized work. Prior to returning any part or machine, the CUSTOMER must obtain a RETURN MATERIAL AUTHORIZATION CODE. Call toll free 1-800-877-1500. This warranty gives the customer specific legal rights as well as other rights which may vary by state. There are no WARRANTIES which extend beyond the face hereof and the warranties set forth above are in lieu of all other warranties, EXPRESS or implied, including any and all implied warranties of merchantability or fitness for a particular purpose, and any other obligation or liability on the part of PIONEER.

PIONEER SHALL IN NO EVENT BE RESPONSIBLE OR LIABLE TO THE OWNER OR ANY THIRD PARTY FOR INDIRECT, SPECIAL OR CONSEQUENTIAL DAMAGES WHETHER ARISING FROM DEFICIENCIES IN THE DESIGN, MANUFACTURE, LABELING OR OPERATION OF THE BRITE STRIPER OR FROM ANY OTHER CAUSE WHATSOEVER AND WHETHER BASED ON TORT, CONTRACT, WARRANTY, STRICT LIABILITY OR OTHERWISE. IN ANY EVENT, PIONEER MANUFACTURING COMPANY INC.'S RESPONSIBILITY IS LIMITED TO THE COST OF THE PRODUCT ITSELF.

No representative employee, agent of Pioneer, or any other person has any authority to assume for Pioneer any additional or other liability or responsibility, other than as described above, in connection with the BRITE STRIPER. Either direct or indirect acceptance of this limited warranty constitutes approval of, and agreement with, all of its terms and conditions by the owner. This limited warranty becomes effective only when all invoices for the Brite Striper have been paid in full.

* The engine and compressor are covered exclusively by the manufacturer's warranty.

also available from
Pioneer®

MAX™

The Ultimate Field Marking Paint

- Exclusive formula includes proprietary brightener for the brightest, whitest lines.
- The brightener are enhanced by video receptors so lines seem to glow on T.V.
- Thicker richer formula is higher in density and solids.
- Enhanced formula performs up to 50% longer.
- Due to more Halogen® 2000 and Optiwite™ optical brightener, lines are up to 500% brighter under UV light and 35% brighter un sunlight.

GameDay®

The Ultimate Field Marking Paint

- Exclusive formula provides the brightest, whitest lines in the industry
- Premium field marking paint for special events, playoffs and high profile teams
- Higher concentration of premium pigment and optical brightener than any other natural turf paint
- Ideal choice for major championships and other nationally televised events

STENCILS

Pioneer's Athletic Field Stencils are made of rugged, easy to use clean plastic for years of use. They are lightweight enough for one person to handle and pre-marked for easy assembly

- Helmet Stencil Kit allows you to customize your field with your schools helmet design.
- Available Stencil Kits: Yardline Stencil Kit, Hash Mark Kit, Letter Stencil Kit.
- Custom Stencils made with our new stencil technology means fewer pieces. Customizing your field has never been as easy or affordable.

P.H.D.

Specially Design Cleaning Concentrate

- Specially designed to clean Pioneer Athletic Field Marking Machines.
- Biodegradable
- Contains no flammable solvents
- Economical - highly concentrated, P.H.D. cleans more at less cost
- Fast Acting - Leaves no soap scum or residue. Keeps your athletic field marker cleaner and brighter longer.



Call 800.877.1500

to order BRITE STRIPER® Accessories

BRITE STRIPE®

ATHLETIC FIELD MARKING PAINT

with Halogen® 2000

Easy to Use

- Homogenized to prevent separation in the container.
- Finely ground ingredients will not clog your machine.

Convenient

- Painted areas are ready to use in one hour.
- Equipment can be washed with soap and water.

Applications

- Football & Soccer Fields
- Walkways • Campsites
- Band Practice Areas
- Tracks • Golf Courses
- Volleyball Courts
- Baseball Fields
- Bicycle Paths
- Grass & Clay Courts
- Grass Parking Areas
- Any grass or paved areas

Packaging

Five gallon pails; One gallon containers, 4 per case.

HIGHLIGHTS

- Premium grade • Now contains Halogen® 2000 for greater brightness • Unsurpassed resistance to severe weather • Fast-drying • Concentrated • Easy-to-use • Professional results • Homogenized for smooth consistency



Improved Formula

- Now 400% brighter under UV light.
- Up to 25% brighter in sunlight.

Save Time & Money

- Bright and durable even when diluted with water up to 4 to 1.

Available in a Variety of Colors

- Pioneer offers 16 standard colors and an unlimited variety of custom colors.
- Customize your fields with your school colors of logo.

Phone: 800.877.1500 www.pioneerathletics.com Fax: 800.877.1511

Pioneer®
"The Striping People"®

4529 Industrial Parkway
Cleveland, OH 44135